



OWNER'S MANUAL

RXV FREEDOM

with IntelliBrake™ Technology

ELITE[™]
LITHIUM

10004455-E

⚠ WARNING

Read and comply with all of the instructions and safety precautions in this manual and on all product labels. Failure to follow the safety precautions could result in serious injury or death.

California Proposition 65

⚠ WARNING

Operating, servicing and maintaining a passenger vehicle or off-road vehicle can expose you to chemicals including phthalates and lead, which are known to the State of California to cause cancer and birth defects or other reproductive harm. To minimize exposure, wear gloves and wash your hands frequently when servicing your vehicle.

For more information go to www.P65Warnings.ca.gov/passenger-vehicle.

Lithium-Ion Batteries

⚠ CAUTION

Improper storage may damage, destroy or cause permanent loss of battery capacity. Do not exceed storage time or temperature limits. Batteries must be charged to the correct level before storage. Storing fully depleted batteries will make them permanently unusable.

The storage time for properly charged Lithium-Ion batteries supplied with this vehicle varies based on the temperature.

Temperature	Length of Storage Time
-22°F to -4°F (-30°C to -20°C)	One month at 100% battery charge, all accessories turned off.
-4°F to 113°F (-20°C to 45°C)	Six months at 100% battery charge, all accessories turned off.
113°F to 140°F (45°C to 60°C)	One month at 30% - 50% charge, all accessories turned off.

⚠ WARNING

Never modify the vehicle in any way that will alter the weight distribution of the vehicle, decrease its stability or increase the speed beyond the factory specifications. Such modifications can cause serious personal injury or death. The manufacturer prohibits and disclaims responsibility for any such modifications or any other alteration which would adversely affect the safety of the vehicle.

OWNER'S MANUAL

48V LITHIUM POWERED RXV FREEDOM

MID MODEL YEAR 2020 - Current

These are the original instructions as defined by 2006/42/EC.

CONTACT INFORMATION

Textron Specialized Vehicles, Inc.
1451 Marvin Griffin Road
Augusta, Georgia, USA 30906-3852

North America:

Technical Assistance and Warranty PHONE: 1-800-774-3946 FAX: 1-800-448-8124

Service Parts PHONE: 1-888-438-3946 FAX: 1-800-752-6175

International PHONE: 001-706-798-4311 FAX: 001-706-771-4609

www.ezgo.com

WELCOME

Thank you for purchasing this vehicle. Before driving your new vehicle, read this owner's guide to familiarize yourself with safe driving practices, operation, features and controls.

This manual contains instructions for minor maintenance only. Information about major repairs can be found in the repair manual. Your dealer has thorough knowledge of your vehicle and wants your total satisfaction with your purchase. We recommend you return to your dealership for all of your service needs during, and after the warranty period.

Repair or replacement parts can be purchased from your dealer or through the manufacturer's parts and accessories department.

TSV maintains the right to change the design of the vehicle without responsibility to make the changes on units purchased before changes were made. The information in this manual can change without notice.

All information in this owner's guide is based on the latest product information at the time of publication. Due to constant improvements in the design and quality of production components, some discrepancies may be found between your vehicle and the information presented in this publication. The content in this publication is intended for reference use only. The manufacturer is not liable for omissions or inaccuracies. Any reprinting or reuse of the content in this publication, whether whole or in part, is expressly prohibited.

Printed in USA

INTRODUCTION

MANUFACTURER'S INTENDED USE 1

WARRANTY AND REGISTRATION 1

BATTERY PROLONGED STORAGE 1

 Storage Preparation 2

 Setting State of Charge (SOC) 2

 During Storage 2

 Extreme Low Temperature Storage 2

 Returning Vehicle to Service 2

BATTERY DISPOSAL 2

VEHICLE SERIAL NUMBER LOCATION 3

SERVICE AND PARTS MANUALS 3

SAFETY LABELS

SAFETY LABELS 5

 Operation (P/N 664789) 5

 Operation (CE) (P/N 614044) 6

 Warning and Operation Label (P/N 608528) 6

 Warning and Operation Label (P/N 608522)(P/N 608522) 6

 Warning and Operation (CE) (P/N 614043) 7

 Tow Bar Label (P/N 635906) 7

 Run/Storage - Tow Label (P/N 609987) 7

 Run/Storage - Tow Label (CE) (P/N 610991) 8

 Grounding Label (CE) (P/N 608818) 8

 Towbar Label (CE) (P/N 612214) 8

 Hot Label (CE) (P/N 608823) 9

 Brake Release (P/N 609694) 9

 Brake Release (CE) (P/N 610990) 9

 Run/Storage-Tow Switch Operation (P/N 612594) 10

 Run/Storage-Tow Switch Operation (CE) (P/N 664283) 10

 Battery Warning (CE) (P/N 659260) 10

SAFETY

SAFETY 11

MAXIMUM WEIGHT CAPACITY 11

TIRE PRESSURE 11

OPERATOR SAFETY 11

 Unauthorized Operation 12

 Operating without Instruction 12

 Alcohol or Drugs 12

 Before Operating 12

 Operating With Passenger or Cargo 13

 Driving in Reverse 13

 Driving a Damaged Vehicle 13

 Driving at Maximum Speeds 13

 Driving on Different Surfaces 13

 Driving on Public Roads 13

 Turning 13

TABLE OF CONTENTS

Driving Uphill	13
Driving Downhill	13
Stalling on a Hill	13
Tires	13
Slippery Terrain	13
BATTERY CHARGING	14
VEHICLE LIFTING	14
VEHICLE MODIFICATION	14
MAINTENANCE SAFETY	14

FEATURES AND CONTROLS

KEY SWITCH /DIRECTION SELECTOR	17
HEADLIGHT SWITCH (IF EQUIPPED)	17
STATE OF CHARGE METER (IF EQUIPPED)	17
HORN (IF EQUIPPED)	17
CUP HOLDER	17
12V OUTLET (IF EQUIPPED)	17
USB PORT (IF EQUIPPED)	17
STEERING WHEEL	17
TURN SIGNAL (IF EQUIPPED)	17
ACCELERATOR PEDAL	17
BRAKE PEDAL	18
PARKING BRAKE	18
SEAT BOTTOM	18
GLOVE BOX / STORAGE COMPARTMENTS	18
CANOPY TOP AND WINDSHIELD	18

OPERATION

SAFETY	19
BEFORE INITIAL USE	19
DAILY INSPECTION	19
ENVIRONMENTAL AWARENESS	19
BATTERY CHARGER	20
PERFORMANCE FEATURES	20
Speed Control	20
Pedal-Up Braking	20
High Pedal Disable Feature	20
STARTING AND STOPPING THE VEHICLE	21
Starting on a Hill	21
ACCELERATING	21
BRAKING	21
Coasting	21
DRIVING PROCEDURE	21
DRIVING WITH A PASSENGER	21
SLIPPERY SURFACES	22
DRIVING UPHILL	22
TRAVERSING HILLSIDES	22
DRIVING DOWNHILL	23
STALLING ON A HILL	23

TABLE OF CONTENTS

DRIVING IN REVERSE	23
PARKING THE VEHICLE	23
MAINTENANCE	
MAINTENANCE SAFETY	25
SCHEDULED MAINTENANCE	25
SCHEDULED MAINTENANCE CHART	25
RECOMMENDED LUBRICANTS AND FLUIDS	26
REPLACEMENT OF MAINTENANCE ITEMS	27
LIFTING THE VEHICLE	28
Lifting Front	28
Lifting Rear	28
Lowering Vehicle	28
VEHICLE CLEANING AND CARE	29
Washing the Vehicle	29
Polishing the Vehicle	29
TIRES	29
Tire Pressure	30
Tire Repair	30
Tire Replacement	30
WHEELS	30
Wheel Removal	30
Wheel Installation	31
LIGHTS	31
LED Headlight Replacement	31
LED Taillight	31
REAR AXLE	32
LITHIUM-ION BATTERY PACK	32
BATTERY CHARGING AND MAINTENANCE	33
BATTERY CHARGING	33
AC Voltage	33
BATTERY PROLONGED STORAGE	34
Storage Preparation	34
BATTERY FAULT DIAGNOSIS	34
TRANSPORTING THE VEHICLE	35
Towing the Vehicle	35
Manual Release of IntelliBrake™	35
Hauling the Vehicle	36
VEHICLE SPECIFICATIONS	
FREEDOM SPECIFICATIONS	38

INTRODUCTION

The following symbols appear throughout this manual and on vehicle labels. Your safety is involved when these symbols are used. Become familiar with their meanings before reading the manual.



DANGER indicates a hazardous situation that, if not avoided, will result in death or serious injury.



WARNING indicates a hazardous situation, if not avoided, could result in death or serious injury.



CAUTION indicates a hazardous situation that, if not avoided, could result in minor or moderate injury.



The **PROHIBITION SAFETY SIGN** indicates an action **NOT** to take in order to avoid hazard.



The **MANDATORY ACTION SIGN** indicates an action that **NEEDS** to be taken to avoid a hazard.



Failure to comply with the warnings in this manual can result in severe injury or death.



Read this entire manual carefully before operating this vehicle. Do not attempt to operate this vehicle until you have thorough knowledge of the controls and features.



Regular inspections and maintenance, along with good operating techniques, will help ensure your safe enjoyment of the capabilities and reliability of this vehicle.

This vehicle was designed and manufactured in the United States of America (USA). The standards and specifications in the following information originate in the USA unless otherwise indicated.

When servicing motors, all adjustments and replacement components must be per original vehicle specifications to maintain the USA Federal and State emission certification applicable at the time of manufacture.

MANUFACTURER'S INTENDED USE

This vehicle is designed and manufactured for off road use only. Use on public streets, roads or highways is illegal in most areas and increases the risk of an accident involving other vehicles and people. This vehicle does not meet FMVSS (Federal Motor Vehicle Safety Standards) for public street, road or highway use.

Check all laws and regulations before choosing an area to operate your vehicle.

WARRANTY AND REGISTRATION

A vehicle warranty statement is included with the purchase of a new vehicle.

Register your new vehicle at www.ezgo.com.

For vehicle warranty transfer, change of address or vehicle ownership, use the form at the end of this owner's manual.

Use Original Equipment Manufacturer (OEM) approved parts to keep the vehicle warranty effective.

Tampering with or adjusting the governor to allow the vehicle to operate above factory specifications will void the vehicle warranty.

All information, including coverage, limitations, exclusions and how to obtain warranty service is included in the literature package with the purchase of the vehicle. It can also be obtained from your dealer.

BATTERY PROLONGED STORAGE

NOTICE: Improper storage may damage, destroy or cause permanent loss of battery capacity. Do not exceed storage time or temperature limits. Batteries must be charged to the correct level before storage. Storing fully depleted batteries will make them permanently unusable.

INTRODUCTION

Storage Preparation

The optimum storage temperature range is between 65°F and 82°F (18°C and 28°C)

- Charge the battery module based on climate during storage period.
 - In cold climates, fully charge the battery module. Make sure that the charging operation is complete and there are no faults displayed on the charger. The green light on the charger should be on, indicating the charge cycle is complete.
 - In hot climates, store the vehicle with a 30% to 50% charge of battery pack capacity.
- Turn the key to the OFF position and remove it from the key switch.
- Check the run - tow switch under the seat, make sure it is set in the RUN position.
- Turn off all accessories.

The storage time for properly charged Lithium-Ion batteries supplied with this vehicle varies based on the ambient temperature.

Temperature	Length of Storage Time
-22°F to -4°F (-30°C to -20°C)	One month at 100% battery charge, all accessories turned off.
-4°F to 113°F (-20°C to 45°C)	Six months at 100% battery charge, all accessories turned off.
113°F to 140°F (45°C to 60°C)	One month at 30% - 50% charge, all accessories turned off.

Setting State of Charge (SOC)

The optional SOC meter or the hand held programmer may be used to determine the state of charge of the battery module. If the SOC is below 30%, charge the battery module until the state of charge reaches 50%. The charge cycle may be interrupted by disconnecting the charger from the AC power source first, then from the charging receptacle on the vehicle. If the SOC is above 50%, operate the vehicle until the SOC is below 50%.

During Storage

Check the state of charge every 30 days. If the SOC is below 30%, charge the battery module until the state of charge reaches 50%.

Extreme Low Temperature Storage

If the ambient temperature is below -4°F (-20°C) DO NOT:

- turn the vehicle key to the ON position
- drive the vehicle
- tow the vehicle
- charge the vehicle
- operate accessories
- turn the lights on (if equipped)

Returning Vehicle to Service

At the end of the storage period, charge the battery module to 100% before operating the vehicle.

Before charging the vehicle be sure that the ambient temperature is between 14°F (-10°C) and 113°F (45°C) and the vehicle has had time to adjust to the temperature.

BATTERY DISPOSAL



Lithium-Ion batteries are recyclable:

- Contact the distributor or manufacturer for information on returning or recycling used or damaged battery packs.
- Contact local or state environmental department for disposal information.
- Refer to the MAINTENANCE section for additional information.

VEHICLE SERIAL NUMBER LOCATION

Four serial number and manufacture date code labels are on the vehicle. One label is located on the steering column. The second label is located on the driver side frame under the front splash shield. The third and fourth labels are located on the passenger side frame rail at the rear of the vehicle. A PIN Number label is located on the passenger side frame under the front splash shield.

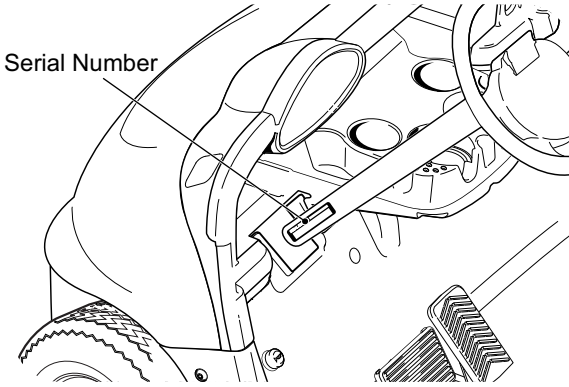

Serial Number Location on Steering Column

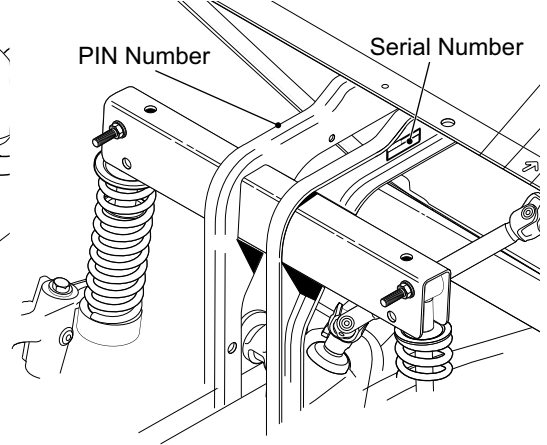

Serial Number Location on Front Frame

Serial Number Labels Part B and D

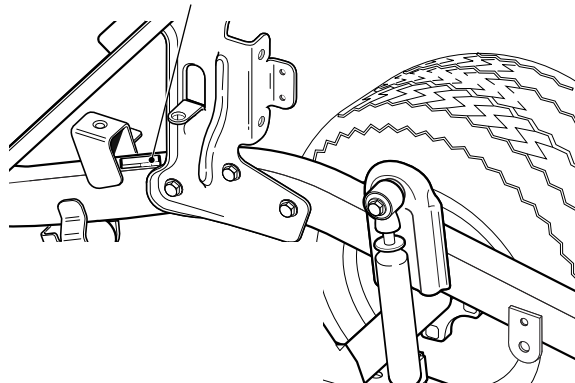

Serial Number Location on Rear Frame

Design changes occur on a continuous basis. To order the correct components for the vehicle, the serial number or PIN and manufacture date are required.

Record the vehicle identification numbers in the spaces provided below. These identification numbers are required when ordering parts.

Vehicle Model Number: _____

Frame PIN: _____

SERVICE AND PARTS MANUALS

The following manuals can be purchased through a dealer:

- service manual
- parts manual

SAFETY LABELS

SAFETY LABELS

Safety and warning labels are on the vehicle for your protection. Read and comply with the instructions on the labels carefully. If any label shown in this manual is different from the label on your vehicle, always follow the instructions on the vehicle label.

If a label comes off or becomes illegible, contact your TSV dealer for a replacement. The part number is provided in this manual, printed on the label, or can be obtained from your dealer.

Operation (P/N 664789)

Located on the steering wheel.



WARNING

READ AND OBEY THE FOLLOWING WARNINGS TO DECREASE RISK OF SEVERE INJURY OR DEATH.

664789



Pressing the accelerator pedal releases the parking brake even when the key is in the OFF position; the vehicle may move when the accelerator pedal is pressed. Unintentional movement of the vehicle can cause injury or death. Do not allow anyone to stand directly in front or behind the vehicle. • Driver must have a valid driver's license. • Do not operate vehicle until all occupants are properly seated with their backs against the seat and feet flat on the floor. • Do not leave children unattended or allow them to play on a parked vehicle.

SAFETY INSTRUCTIONS

BEFORE OPERATING

- READ the owner's manual and all warning labels. Contact an authorized dealer or go to the manufacturer's website for replacement manual or labels. • This vehicle is equipped for personal use in most communities; however, state law or local rules may require additional equipment in your community.

SAFE OPERATION & PARKING

- Turn key to ON, select Forward or Reverse, release the parking brake (if required), and slowly press accelerator pedal. • Always bring vehicle to a complete stop before shifting the direction selector. • Always remain seated in a moving vehicle. • Operate from the driver's seat only. • Never drink alcohol or use drugs or medications before or during operation of the vehicle. • ALWAYS engage the parking brake and remove the key before leaving the vehicle. In an electric vehicle, put the direction selector in OFF or Neutral; in a gasoline vehicle, put the selector in Forward.

MAINTENANCE & TOWING

- This vehicle requires regularly scheduled maintenance (see the periodic service schedule in owner's manual). • ONLY qualified personnel should service this vehicle. • Vehicle is not to be towed; consult owner's manual for transport instructions.

SAFETY LABELS

Operation (CE) (P/N 614044)

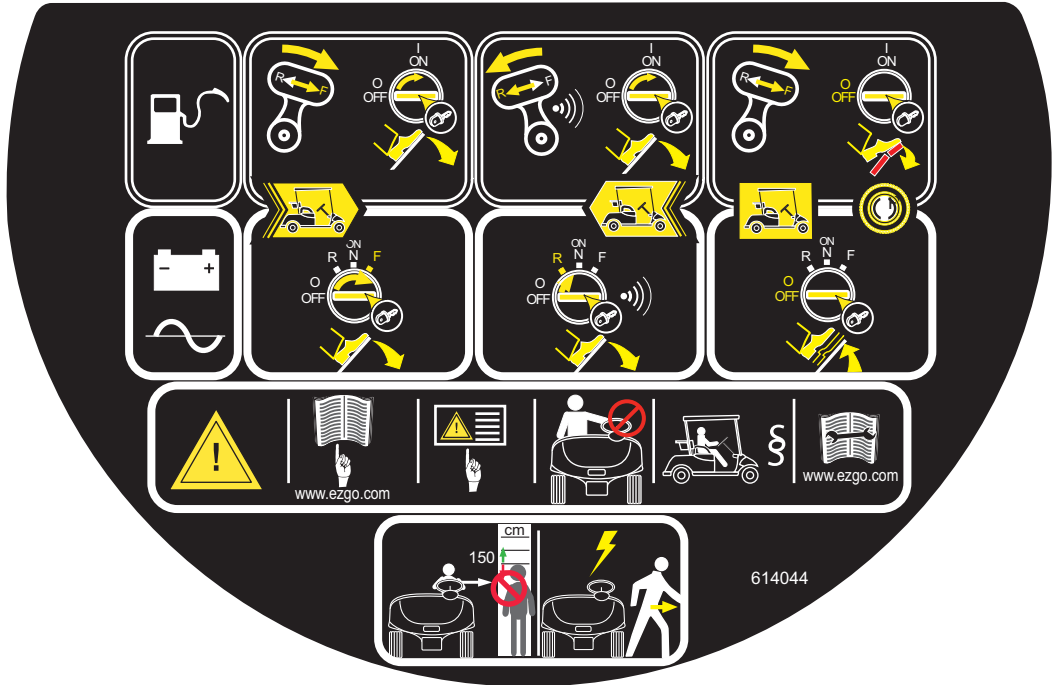

Warning and Operation Label (P/N 608528)

Located on the cup holder.

⚠ WARNING	Failure to follow these instructions can result in SERIOUS INJURY or DEATH
<p>Except where PERMITTED BY LAW: NEVER drive on public roads. • Drivers must possess a valid drivers license in accordance with local state law. 608528</p> <p>AVOID FALLS from the vehicle: Do not start moving until all occupants are PROPERLY SEATED and HOLDING ON. • KEEP entire body INSIDE VEHICLE while moving.</p> <p>Reduce the RISK OF ACCIDENTS: Always DRIVE SLOWLY in congested areas, on wet or loose terrain, and when backing up. • DRIVE SLOWLY when turning and AVOID sudden stops. ALWAYS drive straight up and down slopes. Do not coast, use BRAKE when going down a slope. • NEVER drive this vehicle under the influence of drugs or alcohol.</p> <p>This vehicle is NOT A TOY: Drive responsibly. • NEVER leave children unattended or allow children to play on the vehicle. • NEVER leave the key in the vehicle when parked.</p> <p>DO NOT OVERLOAD this vehicle: NEVER carry more than 2 occupants on each bench seat. • Do not exceed vehicle WEIGHT CAPACITY (see Owner's Manual).</p> <p>DO NOT MODIFY this vehicle: NEVER alter this vehicle to increase travel speeds above factory specifications. • ONLY authorized E-Z-GO dealers should alter the vehicle using approved parts. • Alterations not approved or tested by E-Z-GO can create unsafe conditions and increase your chance of having an accident.</p>	

Warning and Operation Label (P/N 608522)(P/N 608522)

Located on the cup holder.

⚠ WARNING	Failure to follow these instructions can result in SERIOUS INJURY or DEATH
<p>Except where PERMITTED BY LAW: To be operated by persons with valid drivers license, in accordance with state requirements. Operate from Driver's side only. For non-road use, and in designated areas only. Do not operate under the influence of drugs or alcohol.</p> <p>Reduce the RISK OF ACCIDENTS: All occupants must be fully seated, keep entire body inside vehicle and hold on while vehicle is in motion.</p> <p>AVOID FALLS from the vehicle: STARTING the vehicle: Apply service brake, move direction selector to desired position and accelerate smoothly. On Gas Vehicle, direction selector is the F-N-R. On Electric vehicle, direction selector is the key switch.</p> <p>DO NOT OVERLOAD this vehicle: Maximum vehicle payload is 800 lbs. (363 kg) including a maximum of 2 persons, options, and accessories.</p> <p>Drive with CAUTION: Drive slowly straight up and down slopes and in turns. Use care in reverse, congested areas, and wet or loose terrain.</p> <p>STOPPING the vehicle: To stop, release accelerator pedal and apply service brake.</p> <p>PARKING the vehicle: Before leaving vehicle, turn key 'OFF'. On Gas vehicle, move the direction selector to "FORWARD" and engage park brake. 608522</p>	

Warning and Operation (CE) (P/N 614043)

Located on the cup holder.

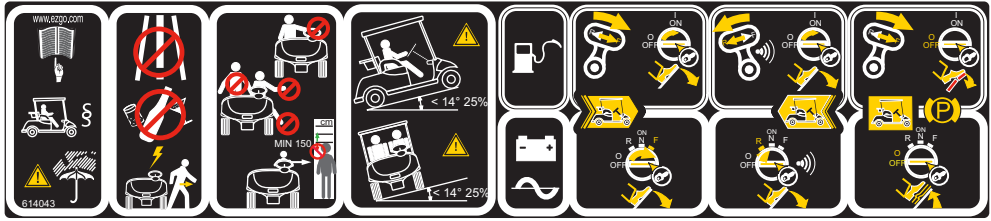

Tow Bar Label (P/N 635906)

Located on the permanent tow bar.

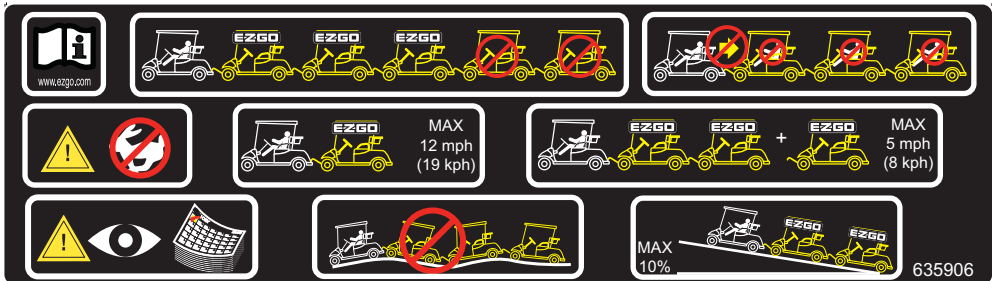

Run/Storage - Tow Label (P/N 609987)

Located on the Run/Storage-Tow cover on the passenger side below the seat.

⚠ WARNING Failure to follow these instructions could result in DEATH or SERIOUS INJURY

IF VEHICLE IS INOPERABLE AND NEEDS TO BE MOVED:

- Turn the ignition key to the 'N' position and 'chock' tires to prevent inadvertent movement.
- Flip the RUN-TOW switch to the 'TOW' position and move vehicle to the desired location and park it properly on level ground and chock tires immediately.
- Turn the ignition key to the 'OFF' position, remove key and perform required service procedures following all Safety Guidelines as outlined in your repair manual.

In Case of Total Power Loss and the 'Run-tow' Switch DOES NOT Release the Brake to Move the Vehicle :

- Remove this plastic cover by removing 3 plastic fasteners. See illustrations below.
- See emergency brake release instruction under this panel.



To reuse fastener push center stem up then install fastener through shield into hole.



To secure fastener in place press down on center stem until flush with head of fastener.

609987

SAFETY LABELS

Run/Storage - Tow Label (CE) (P/N 610991)

Located on the Run/Storage-Tow cover on the passenger side below the seat.

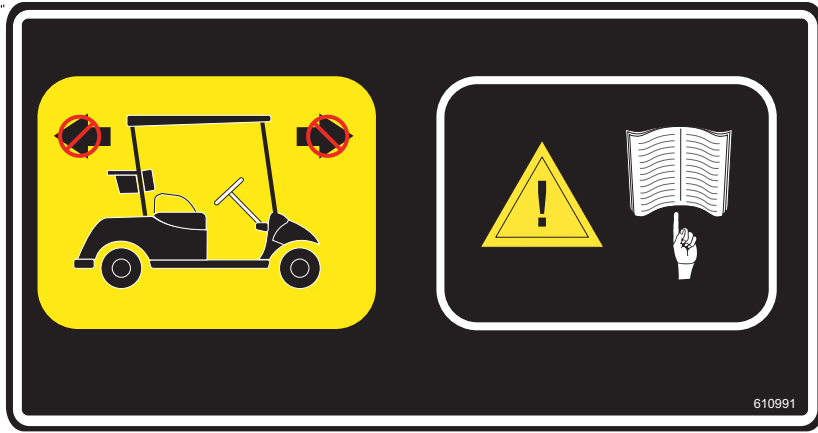

Grounding Label (CE) (P/N 608818)

Located on the rear body seat wrap



Towbar Label (CE) (P/N 612214)

Located on the towbar.

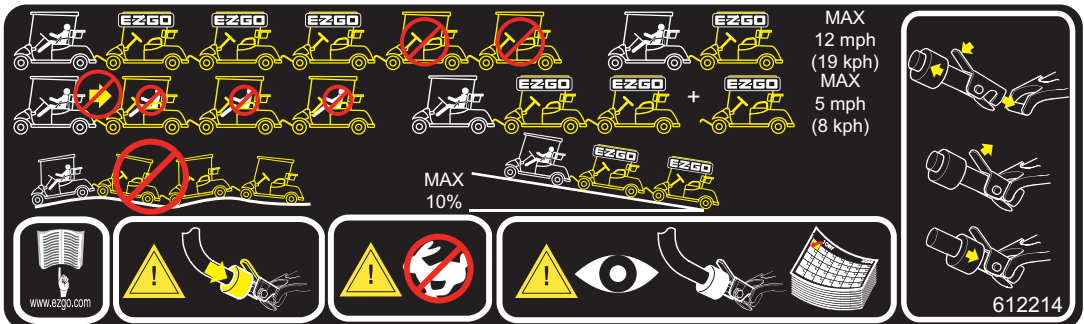

Hot Label (CE) (P/N 608823)

Located on the heat shield.

**Brake Release (P/N 609694)**

Located under the run/storage-tow cover.

WARNING Failure to follow these instructions can result in **SERIOUS INJURY** or **DEATH**

THIS PROCEDURE SHOULD ONLY BE TO CLEAR VEHICLE FROM AN UNSAFE AREA AND BE PERFORMED ONLY BY QUALIFIED TRAINED PERSONNEL

In Case Of Total Power Loss And The 'Run-tow' Switch DOES NOT Release The Brake To Move The Vehicle:

- Turn the ignition key to the 'OFF' position and 'chock' tires to prevent inadvertent movement.
- Identify the 'Auxiliary Power' line (3) and remove the Weather Pack Seal (4) from the connector.
- Identify the 'Primary Power' line (1) connector and disconnect the line (2).
- Connect 'Auxiliary Power' line (3) to 'Primary Power' line (1) which will release the brake. **THIS WILL CAUSE THE VEHICLE TO MOVE IMMEDIATELY IF NOT ON LEVEL GROUND.**
- Move vehicle to desired location and park it properly on level ground, chock tires, **IMMEDIATELY DISCONNECT 'AUXILIARY POWER' AND RECONNECT 'PRIMARY POWER' (1, 2) FOR SAFETY AND TO AVOID BATTERY DRAIN.**
- Reconnect the Weather Pack Seal (4) to the Auxiliary Power line (3) and perform required service procedures following all Safety guidelines as outlined in your repair manual.

609694

Brake Release (CE) (P/N 610990)

Located under the run/storage-tow cover.

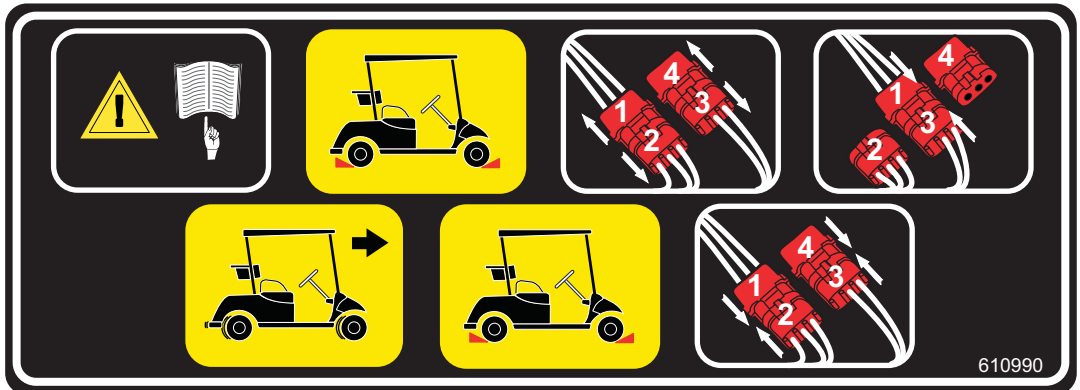

SAFETY LABELS

Run/Storage-Tow Switch Operation (P/N 612594)

Located on the run/storage-tow cover on the passenger side below the seat.

! WARNING

- DO NOT alter or tamper with this unit. Unauthorized modifications can result in **SERIOUS INJURY** or damage to the vehicle and will void the warranty.
- To disable electrical system, turn key switch to 'OFF' and remove battery wires.
-  ALWAYS turn key to 'OFF' before disconnecting or reconnecting battery wires. **ELECTRICAL ARC** or **BATTERY EXPLOSION** can occur if key is not in the 'OFF' position.
- WAIT 30 seconds after reconnecting batteries **BEFORE** turning key switch to 'REVERSE', 'FORWARD' or 'NEUTRAL' positions.

TOWING - Always select 'TOW' position before towing

TOW

○ ←

RUN STORAGE



→ |





612594

Run/Storage-Tow Switch Operation (CE) (P/N 664283)

Located on the run/storage-tow cover on the passenger side below the seat.

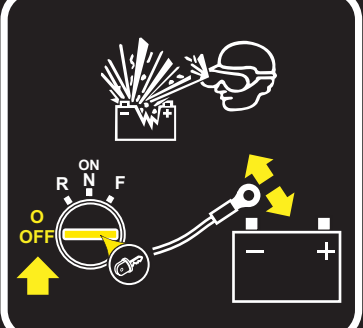



664283

Battery Warning (CE) (P/N 659260)

Located on the battery pack cover.



















659260

SAFETY

SAFETY

For questions about your vehicle or the material in this manual, see the contact information on page i or the back of this publication.

Certain replacement parts can be used independently and/or in combination with other accessories to modify a TSV (Augusta) manufactured vehicle to permit the vehicle to operate at or in excess of 20 mph. When a TSV-manufactured vehicle is modified in any way by the Distributor, Dealer or customer to operate at or in excess of 20 mph on public streets or roads, UNDER FEDERAL LAW the modified product will be a Low Speed Vehicle (LSV) subject to the strictures and requirements of Federal Motor Vehicle Safety Standard 571.500. In these instances, pursuant to Federal law the Distributor or Dealer MUST equip the product with headlights, rear lights, turn signals, seat belts, top, horn and all other modifications for LSV's mandated in FMVSS 571.500, and affix a Vehicle Identification Number to the product in accordance with the requirements of FMVSS 571.565. Pursuant to FMVSS 571.500, and in accordance with the State laws applicable in the places of sale and use of the product, the Distributor, Dealer or customer modifying the vehicle also will be the Final Vehicle Manufacturer for the LSV, and required to title or register the vehicle as mandated by State law.

Information on FMVSS 571.500 is found at Title 49 of the Code of Federal Regulations, section 571.500. For information on-line, go to www.ecfr.gov.

TSV will NOT approve Distributor, Dealer or customer changes that change a TSV product into a Low Speed Vehicle (LSV).

This vehicle meets the current applicable standard for safety and performance requirements.

MAXIMUM WEIGHT CAPACITY



WARNING Exceeding the weight capacities can cause loss of vehicle control and possible injury or death.

Maximum Vehicle Weight Capacity	800 lbs. (363 kg)
---------------------------------	-------------------

- Do not exceed the maximum vehicle weight capacity (includes weight of operator, passenger, cargo and accessories).

TIRE PRESSURE



WARNING Improper tire pressure or uneven tire pressure can cause loss of vehicle control and possible injury or death.

Maintaining correct tire inflation pressure is essential for safe vehicle operation. You can vary the inflation pressure, within the recommended range to suit the condition of the terrain.

TIRE PRESSURE RANGE	TERRAIN CONDITIONS	RECOMMENDATION
18 - 22 psi (124 - 152 kPa)	hard surfaces or pavement	Inflate to higher pressure within the range; never exceed maximum pressure indicated.
	soft terrain or turf	Inflate to lower pressure within the range to reduce potential damage to the terrain or turf.

OPERATOR SAFETY

Safe and responsible use of this vehicle is necessary to prevent dangerous conditions for the operator, passengers and other people in the area of operation. This section of the manual provides information on the safe operation of the vehicle. Make sure you read, understand and comply with all of this information to decrease the risk of personal injury or death.



WARNING Serious injury or death can occur if you do not follow the instructions and procedures shown in this owner's guide.

- Read this entire manual and all product labels carefully. Follow the safety information and operating procedures described.
- Operate your vehicle responsibly to prevent dangerous conditions for the operator, passengers and other people in the area of operation
- Operate your vehicle responsibly and keep the vehicle in safe condition of operation.

SAFETY

- A damaged vehicle, or a vehicle that is not functioning properly is dangerous and must not be operated until repairs are made.
- Keep feet, legs, hands and arms inside the vehicle at all times.
- The driver must keep both hands on the steering wheel and both feet on the floor or pedals.
- Inspect the vehicle before each use to make sure it is in safe operating condition. Perform the Daily inspection described in this manual. See page 19.
- Always have the vehicle checked by an authorized dealer if it is involved in an accident.
- Remove the key when the vehicle is not in use to prevent accidental starting or unauthorized use.
- Drive the vehicle at appropriate speeds for the terrain and conditions. Be aware of environmental conditions that change the terrain and your ability to control the vehicle.
- Do not drive on excessively steep hills. Evaluate the terrain before descending a hill. Drive slowly and deliberately. Use the brake to limit speed and maintain control. Sudden braking or turning can cause loss of vehicle control. Drive straight up or down the hill; do not drive across the hill.
- Operate only in approved areas. Follow all applicable safety rules for the area.
- Avoid driving on terrain that is too rough for your vehicle's capabilities and your driving skills.
- Before you drive in the reverse direction, make sure the area behind the vehicle is clear. Accelerate slowly and avoid making sharp turns.
- Make sure the direction selector is in the correct position before you press the accelerator pedal.
- Decrease speed before and during turns.
- Decrease speed when driving on wet or slippery surfaces.
- Bring the vehicle to a complete stop before you move the direction selector.
- Do not exceed the cargo or vehicle weight capacities. Do not exceed the occupant capacity. See *VEHICLE SPECIFICATIONS* on page 37 for the vehicle load and seat capacity.
- If there is a risk of lightning, leave the vehicle and look for a safe location to wait until the lightning has stopped.

Additional information about safety is included throughout this manual or can be obtained from your local dealer.

WARNING

Failure to operate this vehicle as instructed can cause collision, loss of control or roll-over resulting in severe injury or death. Follow all safety warnings in this owner's manual. See the OPERATION section of the owner's manual for operating procedures and additional safety information.

Unauthorized Operation

Any person who does not have a valid driver's license is not permitted to operate the vehicle.

Any person who is below the height of 59 in. (150 cm) is not permitted to operate the vehicle.

Leaving the keys in the ignition allows unauthorized operation of the vehicle by an unlicensed driver or someone who does not meet the height requirement. Always remove the ignition key when the vehicle is not in operation.

Operating without Instruction



Operation of this vehicle without proper instruction increases the risk of an accident. The operator must understand how to operate the vehicle correctly in different situations and on different types of terrain.

All operators must read, understand and comply with the all warning and instruction labels before operating the vehicle.

Alcohol or Drugs



Operation of the vehicle during or after consuming alcohol or drugs can adversely affect operator judgment, reaction time, balance and perception.

Never drink alcohol or use drugs or medications before or during operation of the vehicle.

Before Operating

Perform the *DAILY INSPECTION* on page 19 before each use to make sure the vehicle is in safe operating condition. Failure to inspect and confirm that the vehicle is safe to operate increases the risk of an accident.

Follow all inspection and maintenance procedures and schedules described in this owner's manual. See *SCHEDULED MAINTENANCE* on page 25.

Operating With Passenger or Cargo

The weight of cargo and occupants affects vehicle operation. Carefully calculate how the vehicle is loaded and how to safely operate it.

Do not exceed weight capacities specified for your vehicle. Capacities are listed in *VEHICLE SPECIFICATIONS* on page 37 of this manual. As passenger weight increases, cargo weight needs to be adjusted to ensure the maximum vehicle weight capacity is not exceeded.

Driving in Reverse

Make sure the area behind the vehicle is clear before operating in reverse. After making sure it is clear and safe to operate in reverse, accelerate slowly. Avoid making sharp turns in reverse. Refer to *DRIVING IN REVERSE* on page 23 for operational information.

Driving a Damaged Vehicle

Driving a damaged vehicle is not safe.

If your vehicle has been involved in any type of accident, have it inspected by a qualified service dealer to verify that it is safe for operation.

Driving at Maximum Speeds

Maximum speed operation increases risk of loss of control. Always drive at a speed that is appropriate for the terrain, visibility, operating conditions and your skill and experience level. Use the brake to control speed and maintain control of the vehicle.

Driving on Different Surfaces

Driving the vehicle on different surface types can affect handling characteristics of the vehicle. When driving on a dirt road, loose surface or wet grass, the distance required to stop the vehicles will increase.

Driving on Public Roads

Driving this vehicle on public streets, roads or highways could result in a collision with another vehicle. Never drive this vehicle on any public street, road or highway, including dirt and gravel roads, unless they are designated for off road use. Most areas prohibit the operation of this vehicle on public streets, roads or highways, and can result in traffic violations and fines.

Turning

Improper or careless turning can cause loss of traction, loss of control, accident or rollover. Do not turn quickly or at sharp angles. Do not turn at high speeds. Practice turning at slow speeds before attempting to turn at faster speeds.

Driving Uphill

Do not climb hills that are too steep for the vehicle or your driving abilities. Loss of vehicle control or rollover can result from climbing hills incorrectly. Refer to *Driving Uphill* on page 22 for operational information.

Driving Downhill

Inspect the terrain before descending a hill. Avoid driving across hills. Use the brake to limit speed and maintain control. Loss of vehicle control or rollover can result from driving downhill incorrectly. Refer to *Driving Downhill* on page 23 for operational information.

Stalling on a Hill

A rollover can result from stalling or rolling backward while climbing a hill. Drive uphill at a constant speed. See procedure on page 23 for maintaining control of your vehicle if it stalls on a hill.

Tires

Operating the vehicle with incorrect tires or with incorrect or uneven tire pressure can cause loss of control or an accident. Always use the size and type tires specified for the vehicle. See *VEHICLE SPECIFICATIONS* on page 37. Always maintain correct tire pressures as specified in *Tire Pressure* on page 11.

Slippery Terrain

Driving on rough, wet or loose terrain increases the risk of loss of traction or control, accident or rollover. Drive slowly and use correct turning procedures when operating on slippery surfaces.

Tires that have lost traction, and then regain traction suddenly, can cause loss of vehicle control or rollover.

Refer to *Slippery Surfaces* on page 22 for operational information.

SAFETY

BATTERY CHARGING

Charging should be performed when ambient temperatures are between 40°F and 110°F (4°C and 42°C). The battery pack may be charged or topped off after every use.

The battery management system (BMS) and charger cooperate to make sure that charging occurs at the proper rate for the battery temperature. When the battery charger is connected to the vehicle, it will determine the charge rate based on the battery temperature. The charger will operate at the rates shown in the table below.

Charge Rate	Temperature
NO charging	below 14° F (-10°C) or above 140°F (60°C)
Pre-charge (charge at reduced rate)	between 14°F (-10°C) and 41°F (5°C) between 104°F (40°C) and 140°F (60°C)
Full charging	between 37.4°F (3°C) and 107.6°F (42° C)

The BMS will adjust the charge rate based on the temperature of the batteries.

Use only the OEM approved Lithium-Ion battery charger for your vehicle. See charger operating instructions in Appendix A.

- Turn the key to the OFF position and remove it from the vehicle.
- Inspect the charger cord for cracks, frayed wires or loose connections. If damaged, replace it.
- Inspect the vehicle charger receptacle and charger plug for dirt, debris or damage. Clean if necessary and replace immediately if damage is found.
- Connect the charger to a wall receptacle. Do not use a multi-plug adapter or power strip. Do not connect anything else to the same receptacle.
- Connect the charger to the vehicle receptacle.
- When the battery pack is finished charging, disconnect the charger cord from the vehicle. If disconnecting before the charge cycle is complete, it is recommended that the charger be disconnected from the wall receptacle first, then unplug the charger from the vehicle receptacle.

VEHICLE LIFTING

The vehicle must be on a firm and level surface for lifting. Remain constantly aware that the vehicle is not stable during the lifting process. Do not get under a vehicle until you verify that it is stable on the jack stands. Never get under a vehicle while it is on a jack only. Put wheel chocks in front and behind the wheels that are not being lifted. Do not allow anyone to remain or get on the vehicle at any time during the lifting process.

Read and comply with all warnings and follow the lifting procedures described on page 28.

VEHICLE MODIFICATION

Do not install any accessory not approved by the manufacturer. Do not modify the vehicle to increase speed or power. Any modifications or installation of accessories not approved by the manufacturer can create a safety hazard and increase the risk of injury.

The warranty will be terminated if the vehicle is modified to increase vehicle speed or power.

The warranty may be terminated if original (or equivalent) replacement parts are not installed on the vehicle.

The addition of some accessories can change the handling characteristics of the vehicle. Use only manufacturer approved accessories, and familiarize yourself with their function and effect on the vehicle.

MAINTENANCE SAFETY

Routine and scheduled maintenance of this vehicle is necessary to keep your vehicle in safe and reliable condition. This section of the manual provides safety information for performing maintenance on your vehicle. Make sure you read, understand and comply with all of this information to decrease the risk of personal injury or death.



WARNING

Serious injury or death can occur if you do not follow the instructions and procedures shown in this owner's manual.

- Read this entire manual and all product labels carefully. Follow the procedures and comply with the safety information in this manual while performing vehicle service or maintenance.
- Use the tools shown in the tool list and wear the specified safety equipment when performing vehicle service or maintenance.
- Remove all jewelry before you service the vehicle.

- Do not allow loose clothing or hair to contact the moving parts.
- Do not touch hot objects.
- The drive wheels must be lifted and supported on jack stands before you perform any service to the power-train while the motor is in operation.
- Use wheel chocks and support the vehicle on jack stands. NEVER get under a vehicle that is supported by a jack. Lift the vehicle following instructions. See *LIFTING THE VEHICLE* on page 28.



- When you service the vehicle, always wear eye protection.
 - Wear a face shield when working around the battery pack.
 - Be careful when working around batteries, using solvents or compressed air.
 - Use insulated tools within the battery area to prevent sparks or battery explosion.
 - To prevent the risk of battery explosion, keep all flammable materials, open flames or sparks away from the battery.
- Maintain constant awareness that some components are heavy, spring loaded, corrosive, explosive, can cause high amperage or get extremely hot.
 - After you make repairs or do maintenance, test the vehicle in a safe area that is free from vehicle and pedestrian traffic.

FEATURES AND CONTROLS

NOTICE: 12V accessories must be connected to the DC to DC converter.

KEY SWITCH /DIRECTION SELECTOR

The key switch/direction selector is a four-position switch.

- OFF - vehicle is disabled.
- ON/N - activates vehicle electronics and accessory power.
- R - allows the vehicle to be driven in reverse, also activates the reverse warning indicator.
- F - allows the vehicle to be driven in the forward direction.

HEADLIGHT SWITCH (IF EQUIPPED)

The headlight switch is a two-position switch.

- upper – on
- lower – off

STATE OF CHARGE METER (IF EQUIPPED)

The state of charge meter is on the dash panel beside the key switch. It indicates the amount of usable power in the batteries, with F indicating a full charge on the battery pack and E indicating low charge. The yellow light indicates the batteries must be charged immediately.

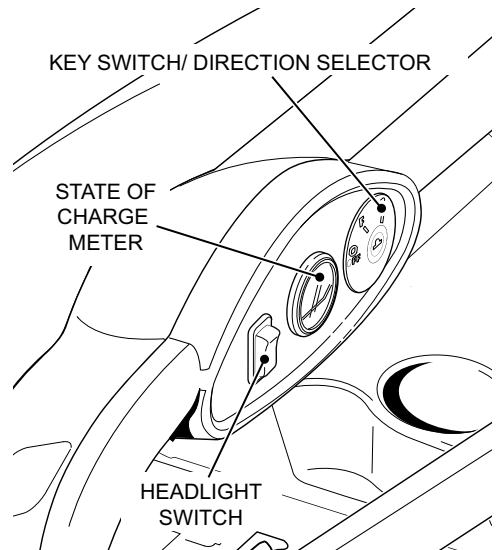

HORN (IF EQUIPPED)

The horn button is located on the driver side of the floorboard. Press the button to activate the horn.

CUP HOLDER

The vehicle has a center cup holder that will accommodate four beverage containers.

12V OUTLET (IF EQUIPPED)



Excessive use of accessories that are connected to the outlet can drain the battery.

A 12V auxiliary outlet is located on the center console.

With the key switch in the ON position, the auxiliary outlet supplies power for any lights and accessories that have a 12V plug.

USB PORT (IF EQUIPPED)

A USB port (if equipped) is located on the center console.

With the key switch in the ON position, the USB port supplies power to electronic devices via a USB cable.

STEERING WHEEL

The steering wheel allows the driver to control the direction of travel.

TURN SIGNAL (IF EQUIPPED)

The turn signal switch is located on the steering column and is used to activate the turn signals.

ACCELERATOR PEDAL

The accelerator pedal is the right pedal on the floorboard. It activates the motor and controls the acceleration of the vehicle.

Apply slow and steady pressure to the accelerator pedal to increase vehicle speed.

FEATURES AND CONTROLS

BRAKE PEDAL

The brake pedal is the left pedal on the floorboard.

Press the brake pedal to slow the speed or bring the vehicle to a complete stop.

PARKING BRAKE

This vehicle is equipped with an IntelliBrake™, an automatic parking brake that is activated when the vehicle is stopped. The brake is released when the vehicle is in the F (forward) or R (reverse) position and the accelerator pedal is pressed.

SEAT BOTTOM

⚠ WARNING To prevent the risk of tipping the vehicle, occupants must fill the front seat prior to filling the rear seat.

The bench seat is designed for two occupants.

Lift up on either hip restraint to pivot the seat bottom forward and access the components underneath. Pivot and lift up on the seat to completely remove it from the vehicle.

GLOVE BOX / STORAGE COMPARTMENTS

The glove box provides storage space for small items. Glove boxes may be equipped with optional doors.

CANOPY TOP AND WINDSHIELD

⚠ WARNING The canopy top does not provide protection from rollover or falling objects.
The windshield does not provide protection from tree branches or moving objects.

NOTICE: To prevent damage to the vehicle, do not hold on to the canopy top struts.

The canopy top and windshield provide some protection from the elements, but do not keep the operator and passenger dry in heavy rain.

This vehicle is not equipped with seat belts, and the canopy top is not designed to provide rollover protection. In addition, the canopy top does not protect against falling objects, nor does the windshield protect against flying objects and tree limbs.

OPERATION

SAFETY



WARNING

Failure to operate the vehicle correctly can result in a collision, loss of control, accident or rollover, and cause serious injury or death. Follow all operation procedures in this section of the manual. Read and comply with all safety warnings in the safety section of this owner's manual.

BEFORE INITIAL USE

To prepare your new vehicle for operation, complete the following:

- Remove the protective plastic from the seats.
- Check for possible leaks that may have developed during shipment of the vehicle.



WARNING

Never charge a vehicle near flammable materials, open flame or sparks. Never charge a vehicle near gas water heaters and furnaces.

- Charge the batteries fully. See Battery Charging in the MAINTENANCE section of this manual.
- Perform the following daily inspection.

DAILY INSPECTION

Inspect and verify that the vehicle is in safe operating condition before each use to decrease the risk of an accident. Check the items in the table to help ensure safe and reliable operation.

Item	Check
Brake system/pedal travel	Check for proper operation.
Parking brake	Ensure vehicle does not roll when the parking brake is engaged.
Front suspension	Inspect. Lubricate if necessary. Check for loose or missing hardware.
Rear suspension	Inspect. Lubricate if necessary. Check for loose or missing hardware.
Steering	Check for smooth and free operation.
Tires	Check condition and pressure. See page 28.
Wheel hardware	Check for loose or missing hardware.
Frame hardware	Check for loose or missing hardware.
Fluid leakage	Inspect vehicle for leaks.
Switches	Check operation.
Reverse warning alarm	Check operation.
Headlights (if equipped)	See page 29.
Brake light / taillights (if equipped)	See page 30.

ENVIRONMENTAL AWARENESS



WARNING

Be careful of potential environmental hazards like steep slopes, rocks, tree branches, etc. that could cause an incident and result in vehicle damage, personal injury or death.

- Always be respectful of the environment.
- Respect all wildlife and their habitat.
- Respect private property and comply with all local laws and regulations governing the use of golf and light duty utility vehicles.
- Make sure you are permitted by property owners to operate the vehicle on their property.

OPERATION

BATTERY CHARGER

NOTICE: *The charger should be operated in accordance with the charger manufacturer's instructions. Always place the charger outside the vehicle before and during the charging cycle (does not apply to on-board charger). Never charge batteries in a hazardous environment.*

DANGER

Risk of electric shock. Connect the charger power cord to an outlet that is correctly installed and connected to an electrical ground according to all codes and regulations. A grounded outlet is necessary to decrease the risk of electric shock – do not use ground adapters or replace the plug. Do not touch parts of output connector or battery terminals that do not have insulation.

Disconnect the AC plug before you make or break the connections to a battery that is charging. Do not open or disassemble the charger. Do not operate the charger if the AC cord is damaged. Make sure qualified personnel does all repair work to the charger.

Refer to APPENDIX A, B or C for the charger manufacturer User's Guide for operating instructions, maintenance instructions and troubleshooting instructions.

The battery charger will test the temperature of the battery pack, if the temperature is too hot or too cold the charger will shutdown. If the battery pack temperature is within the safe to charge range the charger will operate.

PERFORMANCE FEATURES

NOTICE: *The vehicle operates when the run/tow switch is in the RUN position.*

The speed of the motor is sensed and controlled by the controller.

Speed Control

WARNING

The speed control system is not an alternative for the brake. Use the brake to control speed and decrease the risk of injury.

Speed control system vehicles are equipped with a regenerative motor control system.

Example: If all of the following events occur:

- the vehicle is being driven down a slope
- the vehicle attempts to exceed the specified top speed with the accelerator pedal pressed

the regenerative brake will limit the speed of the vehicle to the specified top speed. When the regenerative braking system is activated by this sequence of occurrences, the motor generates power which is returned to the batteries.

Pedal-Up Braking

Pedal-up braking is regenerative braking that occurs when the accelerator pedal is released while the vehicle is moving.

Example: If both of the following events occur:

- The vehicle is being driven down a slope
- The accelerator pedal is released

The pedal-up braking will slow the vehicle until the vehicle stops, or the accelerator is applied. When pedal-up braking system is activated by this sequence of events, the motor generates power that is returned to the batteries.

High Pedal Disable Feature

High pedal disable prevents acceleration if the key is turned on while the accelerator or brake are pressed. To reset the controller after a High Pedal Disable place both feet on the floor, then press the accelerator.

STARTING AND STOPPING THE VEHICLE

All vehicles have an *interlock system* that disables the controller and prevents operation or towing of the vehicle while the charger is connected. Remove the charger plug from the receptacle and correctly store the cable before you move the vehicle.

1. Sit in the driver's seat.
2. Insert the key and turn to the desired direction (F or R).

NOTICE: *When the direction selector is moved to the reverse position, a warning alarm will activate to indicate that the vehicle is ready to run in reverse.*

3. Slowly press the accelerator pedal to start the motor.
4. When the accelerator pedal is released, the motor decreases the speed of the vehicle. To stop the vehicle more quickly, press the brake pedal.
5. Turn the key to the OFF position and remove the key from the switch before exiting the vehicle.

Starting on a Hill

The IntelliBrake™ (parking brake) will activate automatically when the vehicle stops. To start the vehicle on a hill, press the accelerator pedal and the parking brake will be released.

ACCELERATING

⚠ WARNING **Accidental movement of the accelerator pedal can cause the vehicle to suddenly move and cause severe injury or death.**

Apply slow and steady pressure to the accelerator pedal to start the motor and accelerate the vehicle. When you release the accelerator pedal, the motor decreases the speed of the vehicle.

BRAKING

⚠ WARNING **When carrying cargo or towing a vehicle or trailer, the weight of the load will increase the braking distance required to slow or stop the vehicle. Not allowing for increased braking distance under load can cause an accident or injury.**

1. Release the accelerator pedal completely.
2. Press the brake pedal to slow vehicle speed or stop the vehicle completely.
3. Practice slowing and stopping using the brake to become familiar with the controls.

Coasting

The vehicle has a braking feature (pedal-up) that decreases the speed when the accelerator pedal is released. The feature continues to decrease the speed until the vehicle stops. Press the brake if you need to decrease speed or stop the vehicle quickly.

DRIVING PROCEDURE

1. Perform the daily inspection. See page 19.
2. Sit in the driver's seat.
3. Check surroundings and determine the path of travel.
4. Insert the key and turn to the desired direction (F or R).
5. Slowly press the accelerator pedal to start the motor and accelerate.
6. Practice maneuvering the vehicle using the accelerator and brake pedals. Drive slowly and cautiously until you are comfortable with the controls.

DRIVING WITH A PASSENGER

- Do not allow more than one passenger in the vehicle.
- Do not allow a passenger to ride anywhere on the vehicle except the passenger seat.
- Travel at speeds appropriate for your skills, your passenger's skills and the operating conditions. Avoid unexpected or aggressive maneuvers that could cause discomfort or injury to the passenger.
- Handling characteristics can change with the added weight of a passenger. Allow more time and distance for braking.

OPERATION

SLIPPERY SURFACES

⚠ WARNING Skidding or sliding can cause loss of control. Skidding or sliding can cause rollover if tires have lost traction, then regain traction suddenly. When operating on slippery surfaces, travel at reduced speed to help maintain control of the vehicle.

When operating in conditions such as ice, water, muddy trails, loose gravel or freezing temperatures, follow these guidelines:

- Do not operate on excessively rough, slippery or loose terrain.
- Slow down before entering potentially slippery areas.
- Maintain a high level of alertness, carefully evaluate the path of travel and avoid quick, sharp turns.
- Correct a skid by turning the steering wheel in the direction of the skid. *Never apply the brakes during a skid.*

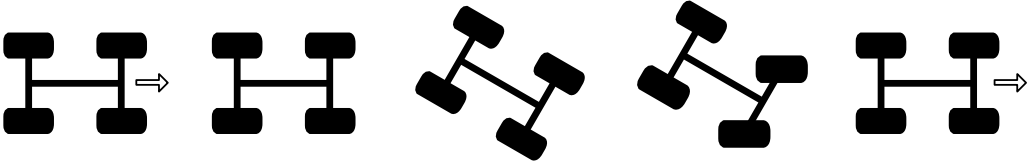

DRIVING UPHILL

When driving up a hill, follow these guidelines:

- Drive straight up the hill.
- Avoid excessively steep hills.
- Keep both feet on the floor or pedals.
- Check the terrain before driving up a hill. Do not try to climb hills that have excessively slippery or loose surfaces.
- Drive at a steady rate of acceleration and speed.
- Do not drive over the crest of a hill at high speed. An obstacle, sharp drop, or another person or vehicle could be on the other side of the hill.
- Do not attempt to drive up a hill that is beyond your skill level.

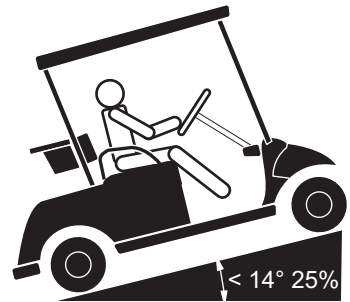

TRAVERSING HILLSIDES

Traversing a hillside is not recommended. Improper procedure can cause loss of control or a rollover. Avoid crossing the side of a hill unless absolutely necessary. If traversing a hillside is unavoidable, check the terrain and determine if it can be accomplished safely. Do not proceed if the terrain is beyond the vehicle or driver's ability.

If traversing a hillside is unavoidable, follow these guidelines:

- Drive slowly.
- Use extreme caution.
- Avoid crossing the side of a hill that has a slippery surface.
- Avoid crossing the side of a steep hill.
- When traversing a hillside that has soft terrain, it may be necessary to steer slightly uphill to keep the vehicle traveling in a straight line.
- If you feel that you are losing control of the vehicle, steer downhill if possible to regain control.

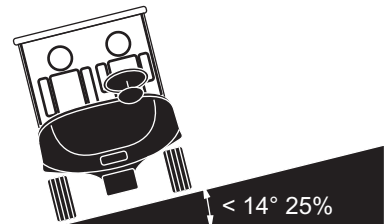

DRIVING DOWNHILL

⚠ WARNING When carrying cargo or towing a vehicle or a trailer, the weight of the load will increase the braking distance required to slow or stop the vehicle. Not allowing for increased braking distance under load can cause an accident or injury.

When driving down a hill, follow these guidelines:

- Avoid excessively steep hills.
- Check the terrain carefully before descending any hill.
- Never drive down hills with excessively slippery or loose surfaces.
- Drive slowly.
- Drive straight down the hill. Avoid descending the hill at an angle that could cause the vehicle to lean sharply to one side.
- Apply light and constant pressure to the accelerator to maintain slow speed and control of the vehicle.

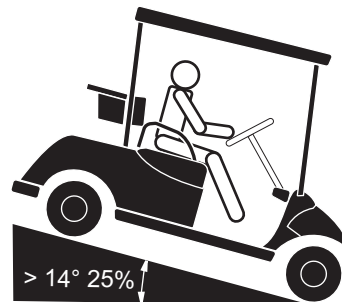

STALLING ON A HILL

A rollover can result from stalling or rolling backward while climbing a hill. Drive uphill at a constant speed.

If your vehicle completely stalls while climbing a hill:

1. Apply the brakes.
2. Verify that the area behind you is clear.
3. Put the vehicle in R (reverse).
4. Use steady accelerator pressure to control speed, and allow the vehicle to slowly roll straight downhill.

DRIVING IN REVERSE

When driving in reverse, follow these guidelines:

- Check that the area behind the vehicle is clear of obstacles and people.
- Check left and right fields of vision before driving in reverse.
- Drive in reverse slowly.
- Press the brakes lightly for stopping.
- Accelerate slow and steady.
- Avoid turning at sharp angles.

PARKING THE VEHICLE

NOTICE: Park the vehicle on a flat surface if possible. If parking on an incline is unavoidable, be sure to chock the wheels to keep the vehicle from rolling.

1. Press the brake to stop the vehicle.
2. Turn the key switch to OFF.
3. Remove the key from the key switch to prevent unauthorized use.

MAINTENANCE

MAINTENANCE SAFETY



To prevent serious injury or death, follow the procedures and comply with the safety information in this manual while performing vehicle service or maintenance.

Do not remove the cover from the battery module(s). There are no serviceable items below the cover.

Use the tools shown in the tool list and wear the specified safety equipment when performing vehicle service or maintenance.

Remove all jewelry before you service the vehicle.

Do not allow loose clothing or hair to contact the moving parts.

Do not touch hot objects.

Before you disconnect or connect a battery module or any other wires, ensure the key is in the OFF position.

The drive wheels must be lifted and supported on jack stands before you do any service to the power-train when the motor is in operation.

Support the vehicle with jack stands. NEVER get under a vehicle that is only supported by a jack. Lift the vehicle according to the manufacturers instructions.

Wear a face shield when working around the battery pack.

Be careful when working around batteries, using solvents or compressed air.

Use insulated tools within the battery area to prevent sparks or battery explosion.

To prevent the risk of battery explosion, keep all flammable materials, open flames or sparks away from the battery.

Maintain constant awareness that some components are heavy, spring loaded, corrosive, explosive, can cause high amperage or get extremely hot.

After you make repairs or do maintenance, test the vehicle in a safe area that is free from vehicle and pedestrian traffic.

NOTICE: To decrease the risk of damage to the controller or motor, move the run/tow switch to the TOW position before you tow the vehicle.

An ELiTE golf car cannot be used to tow vehicles with lead acid batteries. The ELiTE golf car can tow up to three ELiTE model golf cars properly equipped with an approved tow bar system.

After you connect a battery or any other wires, wait a minimum of 30 seconds before you move the switch to the RUN position.

SCHEDULED MAINTENANCE

Consistent inspection, adjustment and lubrication of some components are necessary to maintain your *vehicle* so that it remains in safe and reliable condition. Refer to the *SCHEDULED MAINTENANCE CHART* on page 25 for detailed requirements.

Inspect, clean, lubricate, adjust and replace parts as necessary. Use OEM or equivalent replacement parts.

Record the maintenance items performed, along with details in the *MAINTENANCE LOG* beginning on page 39.

NOTICE: *Service and adjustments are important for safe and reliable vehicle operation. If not familiar with safe service and adjustment procedures, have your dealer perform the operations.*

SCHEDULED MAINTENANCE CHART

Perform all services at the maintenance interval reached first.

MAINTENANCE

S – Indicates operations that need to be performed more frequently on vehicles subjected to severe use.

Item	Interval (perform at interval that comes first)		Remarks	Page
	Rounds	Calendar		
Overall vehicle condition	Daily		Inspect.	
Battery Module	Daily		Charge daily after use.	
Steering	Daily		Check for smooth and free operation.	
Front suspension	Daily		Inspect. Check for leaks and loose or missing hardware.	
Rear suspension	Daily		Inspect. Check for leaks and loose or missing hardware.	
Tires	Daily		Check condition and pressure.	11
Wheel lug nuts	Daily		Check for loose or missing.	30
Accelerator	Daily		Check for smooth operation.	
Brake system	Daily		Check for smooth operation and acceptable stopping distance.	
Headlights and taillights (if equipped)	Daily		Check operation. Replace bulbs as needed.	31
Reverse warning alarm	Daily		Check operation.	
Switches	Daily		Check operation.	
Fluid leakages	Daily		Inspect entire vehicle for leaks	
Charger receptacle	Daily		Clean connections.	
Wiring	20	Monthly	Inspect for loose connections, broken or missing insulation.	
Steering	20	Monthly	Check for excess play, loose or missing hardware.	
S Tie rods	20	Monthly	Check for excess play, bent rods, loose or missing hardware.	
Front suspension	20	Monthly	Inspect strut for leaks. Check hubs and kingpins, for excessive play, worn bushings, loose or missing hardware.	
Rear axle	20	Monthly	Check for leakage; add oil as required.	
Front wheel alignment	60	3 Months	Check for unusual tire wear and adjust if necessary	
Rear Suspension	60	3 Months	Check for shock oil leakage, worn bushings, loose or missing hardware.	
Rear axle	500	5 years	Replace fluid.	

RECOMMENDED LUBRICANTS AND FLUIDS

Check and lubricate all components at the intervals shown in the *SCHEDULED MAINTENANCE CHART* beginning on page 25.

Item	Capacity	Lubricants/Fluids
Rear axle oil	25 oz. (740 ml)	Mobil - 424 - W - ED TSV Part Number 603967
Friction Modifier	2 oz. (60 ml)	Sturaco TSV Part Number 611242

REPLACEMENT OF MAINTENANCE ITEMS

These items or their equivalents can be purchased through your dealer, directly from TSV or any other qualified source.

Item	Part Number
10 A ATC Fuse	35212G07
LED Headlight Assembly	10030334G01 - LH 10030334G02 - RH
LED Taillight	10014910

MAINTENANCE

LIFTING THE VEHICLE

⚠ WARNING Read and comply with all of the following warnings and lifting procedures to prevent the possibility of the vehicle falling and causing serious injury or death.

For some maintenance procedures, it is necessary to lift the vehicle. Comply with the following warnings and follow the lifting procedure to ensure the safety of you, your vehicle and surroundings.

⚠ WARNING The vehicle must be on a firm and level surface for lifting.

Remain constantly aware that the vehicle is not stable during the lifting process.

Place the jack and jack stands only in the areas indicated in the following illustration.

Do not get under a vehicle until it's stability on the jack stands is verified; never get under a vehicle while it is on a jack only.

Put wheel chocks in front and behind all wheels that are not being lifted.

Do not allow anyone to remain or get on the vehicle at any time during the lifting process or when the vehicle is lifted.

When performing any service to the drive-train, lift drive wheels off the ground.

Tools

- jack
- jack stands (4)
- wheel chocks

Lifting Front

1. Chock the rear wheels to keep the vehicle from rolling backward.
2. Put a jack under the center front behind the bumper.
3. Raise the vehicle with the jack.
4. Install a jack stand under the front frame where the instrument panel support is attached to the frame (as shown).
5. Lower the vehicle until it rests on the jack stands.
6. Remove the jack.
7. Confirm that the vehicle is stable on the jack stands before proceeding with any service.

Lifting Rear

1. Chock the front wheels to keep the vehicle from rolling forward.
2. Put a jack under the center of the bag-well.
3. Raise the vehicle with the jack.
4. Install a jack stand under each end of the frame where the leaf spring mounting brackets are welded to the frame (as shown).
5. Lower the vehicle until it rests on the jack stands.
6. Remove the jack.
7. Confirm that the vehicle is stable on the jack stands before proceeding with any service.

Lowering Vehicle

1. Make sure chocks are still in place on any wheels that remain on the ground.
2. Put the jack in the same location that was used to raise the vehicle.
3. Raise the vehicle enough to remove the jack stands. Remove the jack stands from underneath the vehicle.
4. Slowly lower the vehicle to the ground and remove the jack.

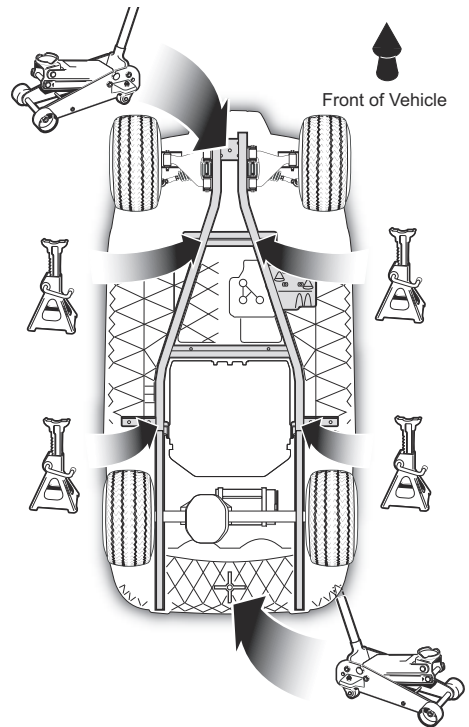

VEHICLE CLEANING AND CARE

Keeping your vehicle clean is not only beneficial to its appearance, but can also help extend the life of various components.

Washing the Vehicle

NOTICE: Do not use a pressure washer to wash your vehicle. High water pressure can damage components.

Some products, including insect repellents and chemicals, will damage plastic surfaces. Do not allow these types of products to contact the vehicle.

- Use an automotive type cleaner or mild soap to wash the vehicle. Harsh cleaners can scratch the finish.
- Use clean or new cloths and pads for washing. Reused cloths and pads can contain dirt particles that will scratch the finish.
- Inspect all grease fittings for dirt intrusion or lack of grease after washing. Apply grease as required to maintain proper function.
- Use a sponge or soft brush and a soap/water solution to clean the vinyl seats. Rinse with clean water.
- Use an automotive type wash cloth to wash the body of the vehicle. To prevent the soap from drying on the vehicle, rinse with clean water frequently.
- Clean the windshield with water and a clean cloth. Remove small scratches with a plastic polish.
- Clean the bottom of the vehicle where mud or dirt can collect. Loosen any packed sediment to help with removal. Be careful not to damage the paint.
- Dry the vehicle with a chamois before the water dries to prevent water spots.

Polishing the Vehicle

- Do not use medium to heavy duty compounds on the finish. Use wax that is for clear coat automotive finishes only. Do not apply wax or polish to matte finish surfaces.
- Use clean or new cloths and pads for polishing. Old or reused cloths and pads can contain dirt particles that will scratch the finish.

TIRES

Follow the tire maintenance procedures as instructed in this manual and on the labels on the vehicle.

Always use approved size and type of replacement tires. See *VEHICLE SPECIFICATIONS* on page 37.

WARNING

Worn, improperly inflated, improper sized, or incorrectly installed tires will affect vehicle handling and could cause an accident resulting in severe injury or death.

Inflate all tires to the same pressure. Operating with unequal or incorrect pressure can adversely affect steering and handling and could cause an accident resulting in severe injury or death.

To decrease the risk of tire explosion, do not exceed the tire inflation rating on the tire sidewall. Make sure the tires are properly inflated at all times of operation.

To decrease the risk of tire explosion, inflate small amounts of air into the tire at intervals to allow the beads to seat properly. Because of the low volume of the small tires, over inflation can occur in seconds. Never exceed the tire inflation pressure rating on the tire sidewall when seating a bead. Protect your face and eyes when you remove a valve core.

When you remove the wheels, use only sockets made for impact wrenches to decrease the risk of injury by a broken socket.

Do not use tires with low rated pressure. Do not use tires that have a recommended tire inflation pressure less than the tire inflation pressure recommended in the owner's guide.

Do not over inflate the tires. Excess pressure can cause the tire to separate from the wheel or cause a tire explosion.

MAINTENANCE

Tire Pressure

Maintaining correct tire inflation pressure is essential for safe vehicle operation. You can vary the inflation pressure, within the recommended range to suit the condition of the terrain.

TIRE PRESSURE RANGE	TERRAIN CONDITIONS	RECOMMENDATION
18 - 22 psi (124 - 152 kPa)	hard surfaces or pavement	Inflate to higher pressure within the range; never exceed maximum pressure indicated.
	soft terrain or turf	Inflate to lower pressure within the range to reduce potential damage to the terrain or turf.

Tire Repair

NOTICE: Tire repairs are not covered under the vehicle warranty.

Tools

- lug wrench, 3/4"
- impact socket, 3/4"
- impact wrench
- torque wrench, ft.lbs.

NOTICE: Tire plug tools and plugs are available at automotive outlets. The tire does not have to be removed from the wheel to install the tire plug.

Use a tire plug to repair small holes in the tread part of the tire. For large holes or holes/cuts in the tire sidewall, the tire must be replaced.

1. Remove the wheel from the vehicle. See *Wheel Removal* on page 30.
2. Locate the leak in the tire.
 - a. If the tire is very low or flat, fully inflate the tire.
 - b. Brush soapy water over the surface of the tire. Air bubbles will be visible where the air is leaking from the tire.
 - c. Mark the hole with chalk.
3. Install the plug according to the manufacturer's instructions.
4. Install the wheel on the vehicle. See *Wheel Installation* on page 31.
5. Fully inflate the tire. See *Tire Pressure* on page 11.

Tire Replacement

Tire replacement requires a tire mounting machine and must be done by a qualified tire center or your dealer.

WHEELS



WARNING

Worn, improperly inflated, improper sized, or incorrectly installed tires will affect vehicle handling and could cause an accident resulting in severe injury or death.

NOTICE: To decrease the risk of component damage, do not tighten the lug nuts to more than the torque specified below.

Check lug nuts for tightness at the intervals indicated in the *SCHEDULED MAINTENANCE CHART* on page 25.

Wheel Removal

Tools

- lug wrench, 3/4"
- impact socket, 3/4"
- impact wrench
- torque wrench, ft.lbs.

1. Lift the vehicle. See *LIFTING THE VEHICLE* on page 28.
2. Remove the lug nuts.
3. Remove the tire from the vehicle.

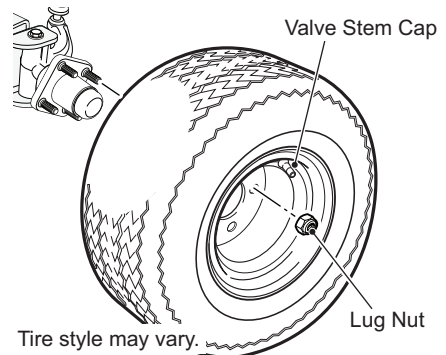

Wheel Installation

Lug Nut Torque	50 - 85 ft.lbs. (68 - 115 Nm)
----------------	-------------------------------

NOTICE: To decrease the risk of component damage, do not tighten the lug nuts to more than the specified torque.

Always install lug nuts using a cross sequence pattern to ensure even seating of the wheel against the hub.

1. Install the wheel on the hub with lug nuts. Make sure the valve stem is to the outside.
2. Finger tighten the lug nuts.
3. Using the tightening pattern shown at right, tighten the lug nuts to 50 - 85 ft.lbs. (68 - 115 Nm). Tighten in increments of 20 ft. lbs. (27 Nm).

Lug Nut Tightening Pattern

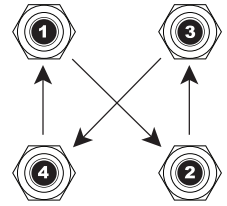

LIGHTS

- Clean the lights frequently to maximize visibility.
- Replace burned out lights promptly.

CAUTION Do not operate this vehicle at night or in low light if any lights are burned out. Poor lighting reduces visibility that could cause an accident resulting in severe injury or death.

LED Headlight Replacement

CAUTION Light components can get hot if they have been in operation. Allow the lights to cool before servicing to prevent burns to the skin.

Make sure the vehicle key switch is in the OFF position and the key has been removed from the switch.

1. Disconnect the accessory harness from the headlight.
2. Align the headlight with the opening in the back of the headlight assembly along with gasket.
3. Secure headlight to the cowl using four headlight clips.
4. Reconnect the accessory harness to the headlight.

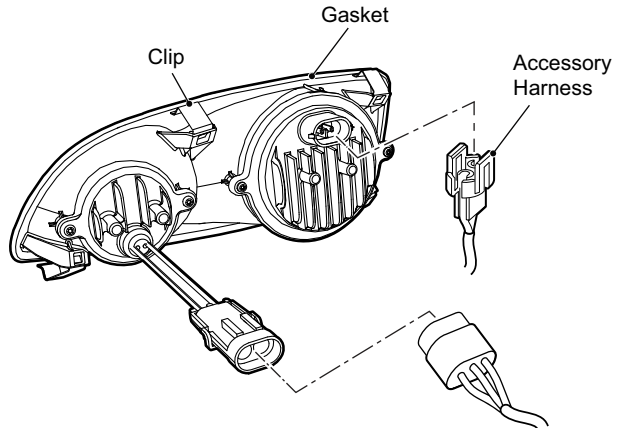

LED Taillight

Make sure the vehicle key switch is in the OFF position and the key has been removed from the switch.

1. Remove three screws that secure the taillight to the bezel.
2. Remove the taillight.
3. Install the new taillight and secure the taillight using three screws.

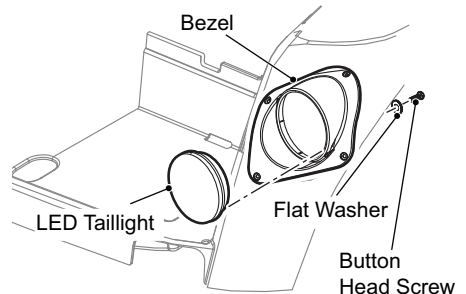

MAINTENANCE

REAR AXLE

The only maintenance necessary for the first five years is the inspection of the rear axle for lubricant leakage. Unless leakage is visible, the lubricant needs to be replaced after five years. Refer to the Service and Repair Manual for the fluid replacement procedure.

Change the axle oil at the intervals indicated in the *SCHEDULED MAINTENANCE CHART* on page 25. The drain plug is located at the bottom of the rear axle housing.

LITHIUM-ION BATTERY PACK

Charge the battery pack using only the OEM approved Lithium-Ion battery charger.



WARNING

Improper handling of batteries and electrical components can result in serious injury or death.

Do not attempt to remove batteries or battery cables. Do not use the battery pack without the control module installed. All battery and electrical service must be performed by an authorized service facility.

All tools used in or around the battery pack area should be insulated. Do not intentionally cause a short to the power terminal (P+, P-, B+, B-) with a metallic object.

Do not use the vehicle or charge the battery pack if the battery pack has become abnormally hot, is discolored, deformed, leaking or has an odd odor. If liquid from the battery pack leaks onto skin or clothes, wash well immediately with fresh, running water. If liquid gets into the eyes, do not rub the eyes. Wash the eyes with fresh, running water and seek medical assistance immediately.

Do not disassemble or modify the design, including the electrical circuit, of the battery pack or control module.

To prevent the risk of battery explosion, keep all flammable materials, open flames or sparks away from the batteries. Do not leave the battery pack near a fire or heat source. Do not throw Lithium-Ion batteries into a fire. Do not apply heat to any part of the battery pack or battery management module with a soldering iron. Do not place the battery pack in a microwave oven, dryer or high-pressure container.

Make sure that the key switch is in the OFF position and the run/tow switch is in the RUN position before you start to work on the vehicle.

Do not attempt to operate the vehicle or charge the battery pack at temperatures above 140°F (60°C).

Do not immerse or throw the battery pack in water. Do not pressure wash the battery pack.

Do not puncture the battery pack or control module. Do not strike the battery pack with a hammer or heavy weight. Do not step or stand on the battery pack. Do not throw or drop the battery pack on hard surfaces.

If the battery pack terminals are contaminated or dirty, clean them with a dry cloth before using the battery pack.

Keep the battery pack and control module away from static electricity.



WARNING

Before recycling or shipping battery pack, make sure that the battery pack terminals are insulated.



Lithium-Ion batteries are recyclable:

- Return discarded batteries to distributor or manufacturer for recycling.
- Contact local or state environmental department for the disposal information.
- Refer to the Maintenance section for additional information.

BATTERY CHARGING AND MAINTENANCE



WARNING

Do not attempt to start the vehicle or charge the battery pack if the vehicle has been stored at or below freezing temperatures.

NOTICE: Do not spray the battery module with water. Do not attempt to add water to the battery module.

Do not charge the batteries if the ambient temperature is below -4°F (-20°C) or above 113°F (45°C). Refer to Appendix A for battery charger operating instructions.

Before connecting the battery charger:

- Park the vehicle, turn the key switch to OFF and remove the key.
- Inspect the charging receptacle for dirt or debris. Remove dirt or debris if found.
- Inspect the charger cords and plugs for cracks or damage. Replace any damaged cords before use.
- Plug the charger into a receptacle on a dedicated circuit. Do not connect any other devices to the receptacle.
- Connect the charger to the vehicle.

BATTERY CHARGING

The battery charger is designed to completely charge the battery set. If the batteries are severely discharged the charger will indicate a fault. The automatic charger determines the correct length of charge for the battery set and turns off when the batteries are charged. Always refer to the instructions supplied with the charger. See Appendix A for charger operating instructions.

AC Voltage

The battery charger output is directly related to the input voltage. If the vehicle receives an incomplete charge in a normally adequate time period, low AC voltage can be the cause. Consult an electrician if necessary.

MAINTENANCE

BATTERY PROLONGED STORAGE



Improper storage may damage, destroy or cause permanent loss of battery capacity. Do not exceed storage time or temperature limits. Batteries must be charged to the correct level before storage. Storing fully depleted batteries will make them permanently unusable.

Storage Preparation

The optimum storage temperature range is between 65°F and 82°F (18°C and 28°C)

- Charge the battery module based on climate during storage period.
 - In cold climates, fully charge the battery module. Make sure that the charging operation is complete and there are no faults displayed on the charger. The green light on the charger should be on indicating the charge cycle is complete.
 - In hot climates, store the vehicle with a 30% to 50% charge of battery pack capacity.
- Turn the key to the OFF position and remove it from the key switch.
- Check the Run - Tow switch under the seat, make sure it is set in the RUN position.
- Turn off all accessories.

The storage time for properly charged Lithium-Ion batteries supplied with this vehicle varies based on the ambient temperature.

Temperature	Length of Storage Time
-22°F to -4°F (-30°C to -20°C)	One month at 100% battery charge, all accessories turned off.
-4°F to 113°F (-20°C to 45°C)	Six months at 100% battery charge, all accessories turned off.
113°F to 140°F (45°C to 60°C)	One month at 30% - 50% charge, all accessories turned off.

BATTERY FAULT DIAGNOSIS

Refer to the charger instructions in Appendix A, B or C.

TRANSPORTING THE VEHICLE



WARNING Do not ride on or allow other people on a vehicle being transported on a trailer or being towed with another vehicle.

Towing the Vehicle



WARNING Do not try to tow the vehicle with ropes, chains or any device different from a tow bar approved by the manufacturer. Use an golf car with an approved tow bar system to tow the vehicle.

Do not tow the vehicle on highways.

Do not tow the vehicle at speeds more than 12 mph (19 kph).

Do not tow more than three Elite vehicles at one time.

1. Turn the key switch to N (neutral).
2. Chock the wheels to keep the vehicle from moving.
3. Connect the vehicle to the tow bar and remove the wheel chocks.
4. Place the run/tow switch in the TOW position, the vehicle should roll freely.

NOTICE: This vehicle is equipped with an IntelliBrake™ for parking. When the vehicle is stopped, the parking brake is automatically set. The IntelliBrake™ is released when the vehicle is in F (forward) or R (reverse) and the accelerator is pressed. The IntelliBrake™ is also released when the run/tow switch is in the TOW or  (on European Models) position with the key switch turned to N (neutral).

Manual Release of IntelliBrake™

In case of total power loss and the RUN/TOW switch does not release the IntelliBrake™, use the instructions under the controller splash shield. Chock the tires to prevent the vehicle from moving when the brake is released.

To read the instructions, remove three re-usable plastic rivets that secure the controller splash shield to the body and the controller. To remove these rivets, press the center of the rivet with the vehicle key. When the center pin goes into position, the rivet can be removed. Repeat the procedure for each remaining rivet. Turn the splash shield over to read the instructions.

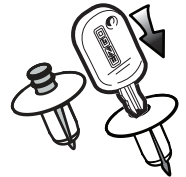

Make sure that the key switch is in the OFF position and chock the tires to prevent the vehicle from moving; Then do the following:

1. Locate the 'Auxiliary Power' line (7) and remove the weather pack seal (8) from the connector.
2. Locate the 'Primary Power' line connector (5) and disconnect it from line (6).
3. Connect the 'Auxiliary Power' line (7) to the 'Primary Power' line (5) which releases the brake. If the tires are not chocked and the vehicle is not on flat ground, the vehicle will move immediately.
4. Move the vehicle to desired, safe location and chock the tires immediately.
5. Disconnect the 'Auxiliary Power' line (7) from the 'Primary Power' line (5).
6. Connect the 'Primary Power' line (5) to line (6).
7. Replace the weather pack seal (8) on the 'Auxiliary Power' line connector (7).

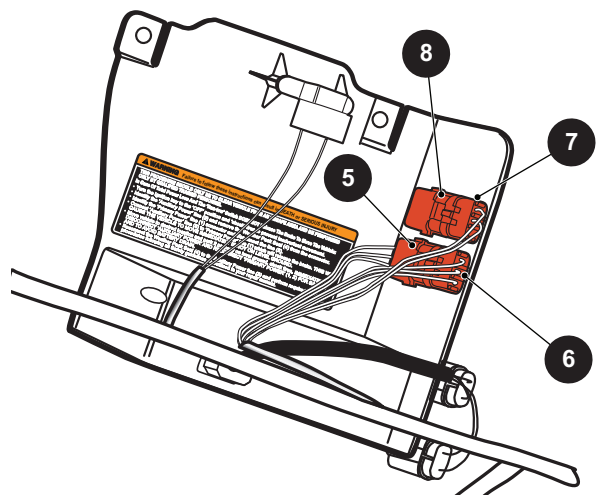

MAINTENANCE

8. To reinstall the controller splash shield, position the splash shield by aligning the mounting holes with the holes in the body, push the center pin of each rivet upward so that the top of the pin is above the rivet head.
9. Place a rivet in each mounting hole of the controller splash shield and push down on the center pin until the top of the pin is flush with the rivet head.

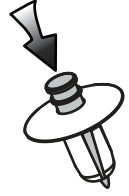

Hauling the Vehicle

WARNING Loose cargo or vehicle components can fly off when the vehicle is being transported. Secure or remove all cargo. Inspect the vehicle for loose components prior to transport.

Do not allow anyone to ride in a vehicle being transported on a trailer.

Remove the windshield and top before you transport a vehicle on a trailer.

- If the vehicle is being hauled on a trailer or truck, the canopy top and windshield must be removed.
 - The rated capacity of the hauling trailer or truck must be more than the weight of the vehicle and load plus 1000 lbs. (454 kg). See GENERAL SPECIFICATIONS for the weight of the vehicle.
1. Drive the vehicle onto the trailer or truck.
 2. Engage the parking brake. Leave the direction selector in F (forward).
 3. Turn the key to the OFF position.
 4. To prevent loss of the key, remove it from the ignition switch.
 5. Make sure the seat(s) are secured.
 6. Secure the vehicle to the trailer or truck with tie downs, straps or ropes.

VEHICLE SPECIFICATIONS

SPECIFICATIONS

FREEDOM SPECIFICATIONS

Item	Specification
Maximum Weight Capacity (includes weight of operator, passenger, cargo, accessories)	800 lbs. (363 kg)
Seating Capacity	2 person
Weight (No Batteries)	615lbs. (3279 kg) without batteries
Curb Weight	662 lbs. (302 kg) with Single Pack
Outside Clearance Circle	19.2 ft. (5.9 m)
Speed (Level Ground)	12 - 19 mph (19 - 31 kph)
Towing Capacity	3 ELiTE Golf Cars with approved tow bars
Overall Length	94.5 in (240 cm)
Overall Width	47.0 in. (119 cm)
Overall Height (no canopy)	46.5 in. (118 cm)
Overall Height (with canopy)	69.5 in. (177 cm)
Wheelbase	66 in. (168 cm)
Track Width (front)	34.5 in. (88 cm)
Track Width (rear)	38.5 in. (98 cm)
Ground Clearance at Differential	4 in. (10 cm)
Power Source	56.7 VDC
Motor Type	56.7 VAC
Battery Quantity and Type	Single, 56.7 Volt Li-Ion Composite Module (Standard Configuration)
Electrical System	56.7 VDC
Horsepower (kW)	4.4 hp (3.3 kW) Continuous
Key or Pedal Start	Pedal
Speed Controller	235 Amp AC Controller
Drive Train	Motor Shaft Direct Drive
Trans-axle	Limited Slip Differential
Gear Selection	Dash Mounted Forward-Neutral-Reverse
Rear Axle Ratio	16.99:1
Steering	Double Ended Rack and Pinion
Front Suspension	Independent A-Arm Coil Over Shock
Rear Suspension	Mono-Leaf Springs with Hydraulic Shocks
Service Brake	Induction Motor
Parking Brake	Automatic Electro-Magnetic
Front Tires	18 X 8.50 - 8 (4 Ply Rated)
Rear Tires	18 X 8.50 - 8 (4 Ply Rated)
Frame	Welded Steel with DuraShield™ Powder Coat
Body and Finish	Injection Molded TPO
Turning Radius	9.6 ft (2.9 m)
CE Noise, Vibration and Harshness	Measurement methods were applied per the ISO 2631 and ISO 5349 standards under conditions of typical vehicle surfaces.
Noise	Sound pressure: continued A-weighted equal to or less than 68 db (A)
Vibration, WBV	The highest RMS value of weighted acceleration is: 1.15 m/s ²
Vibration, HAV	The highest RMS value of weighted acceleration is: 2.5 m/s ²
	The uncertainty of measurement is 0.2 m/s ²

MAINTENANCE LOG

DATE	MILES (KM) AND HOURS	TECHNICIAN	SERVICE PERFORMED COMMENTS

APPENDIX A

BATTERY CHARGER USER'S GUIDE



1 kW Industrial Battery Charger

QuiQ Charger - E-Z-GO Product Manual

This manual contains important safety and operating instructions for versions of the Delta-Q QuiQ (Model nos. 913-4830-E3/-E3B/-E5 /-E5B) installed on E-Z-GO brand vehicles. Please read this information before using your QuiQ Charger. For manufacturer contact information and technical support resources, please visit delta-q.com/support

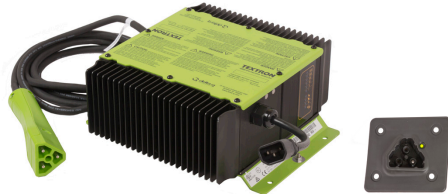

SAVE THESE IMPORTANT SAFETY INSTRUCTIONS - This manual contains important safety and operating instructions – read before using charger.

INFORMATIONS IMPORTANTES DE SÉCURITÉ Ce manuel contient des instructions importantes concernant la sécurité et le fonctionnement.



Warning

Charge only 48 Volt Lithium-Ion type batteries activated by Samsung SDI. Other types of batteries may burst causing personal injury and damage. Never charge a frozen battery. Study the battery manufacturer's specific precautions.



Attention

Recharger uniquement les batteries de type Lithium-Ion 48V activées par Samsung SDI. Autres types de batteries pourraient exploser causant des blessures corporelles et des dommages. Ne jamais charger une batterie gelée. Prendre connaissance des mesures de précaution spécifiées par le fabricant de la batterie.



Danger

Risk of electric shock. Connect charger power cord to an outlet that has been properly installed and grounded in accordance with all local codes and ordinances. A grounded outlet is required to reduce risk of electric shock – do not use ground adapters or modify plug. Do not touch uninsulated portions of output connector or uninsulated battery terminals. Disconnect the charger from either the AC supply or from the golf cart, before making or breaking the connections to the battery. Do not open or disassemble charger. Do not operate this charger if the AC supply cord is damaged or if the charger has received a sharp blow, been dropped, or is damaged in any way – refer all repair work to the manufacturer, or qualified personnel. This charger is not intended for use by persons (including children) with reduced physical, sensory or mental capabilities, or lack of experience and knowledge on electrical systems and battery charging, unless they have been given supervision or instruction concerning use of the charger by a person responsible for their safety. Children should be supervised to ensure that they do not play with the charger.



Danger

Risque de décharge électrique. Ne pas toucher les parties non isolées du connecteur de sortie ou les bornes non isolées de la batterie. Toujours connecter le chargeur à une prise de courant mise à la terre. Déconnectez la source AC avant de faire ou défaire les connexions à la batterie en chargement. Ne pas utiliser le chargeur si le cordon d'alimentation AC est endommagé ou si le chargeur est abimé suite à une chute ou autre incident. Ne pas ouvrir ni désassembler le chargeur – référer toute réparation aux personnes qualifiées. Cet appareil n'est pas destiné à un usage par des personnes (dont les enfants) avec des facultés motrices, sensorielles ou mentales réduites, ou ayant une expérience et des connaissances insuffisantes, à moins qu'elles sont sous la supervision ou reçoivent les instructions sur l'utilisation de l'appareil d'un répondant garant de leur sécurité. Les enfants devraient être surveillés afin qu'il ne jouent en aucun temps avec l'appareil.

Maintenance Instructions

1. Do not expose charger to high pressure water spray when cleaning vehicle.
2. The enclosure of the charger meets IP66, making it dust-tight and protected against powerful water jets. The AC connection is rated to IP20, which is not protected against water. Protect the AC connection if used in wet or dusty environments.
3. If the detachable input power supply cord set is damaged, replace with a cord that is appropriate for your region:
 - ✦ This charger is provided with a cord set for connection to outlets operating at nominal 120 Volts (or 240 Volts as appropriate). If the input plug does not fit the power outlet, contact Delta-Q Technologies for the proper cord set terminating in an attachment plug of the proper configuration for the power outlet.
 - ✦ North America: UL or CSA listed / approved detachable cord, 3 conductor, 16AWG minimum and rated SJT; terminated in a grounding type IEC 60320 C14 plug rated 250V, 13A minimum
 - ✦ For all other regions: Safety approved detachable cord, 3 conductor, 1.5mm² minimum, rated appropriately for industrial use. The cord set must be terminated on one end with a grounding type input connector appropriate for use in the country of destination and, on the other end, an output grounding type IEC 60320 C14 plug.

Operating Instructions

CAUTION: Charger enclosure may be hot during charging. Use hand protection if handling the charger while charging.

- + Extension cords must be 3-wire cord no longer than 30m(100') at 10AWG or 7.5m(25') at 16AWG per UL guidelines.
- + Only connect **ONE** QuiQ charger to a single 15A circuit or the circuit may become overloaded.

Ammeter

Displays scale of output current

- + If only ammeter and AC Indicator LEDs are lit: Less than 80% state of charge
- + If flashing: Output has been reduced due to high internal charger temperature.



Charger 10-LED Display

Charge Indicator (Orange Light)

- + If solid: Greater than 80% state of charge
- + If off: Less than 80% state of charge or pre-charge

Charge Completion Indicator (Green Light)

- + If solid: Charging is complete

AC Indicator (Orange Light)

- + If solid: AC power is present.
- + If flashing: Low AC voltage. Check electrical source and cord length.

Fault Indicator (Red Light)

- + Charger error. Refer to troubleshooting information below.



Receptacle Display

LED	Indication
Solid	Charge complete
Long flash	Greater than 80% state of charge
Short flash	Less than 80% state of charge
Off	See charger for indications.

Troubleshooting Instructions

If a fault occurs, count the number of red flashes between pauses and refer to the table below.

Flashes	Cause	Solution
Ⓜ 🔴 🔴 Ⓜ	Charger unable to apply wake-up pulse	Refer cart to service department
Ⓜ 🔴 🔴 🔴 🔴 Ⓜ	Charge timeout	Possible BMS error - refer cart to service department
Ⓜ 🔴 🔴 🔴 🔴 🔴 Ⓜ	BMS fault	Refer cart to service department
Ⓜ 🔴 🔴 🔴 🔴 🔴 🔴 Ⓜ	Charger shutdown due to high internal temperature.	Ensure sufficient cooling airflow. Reset the charger by interrupting AC power for 15+ seconds.
Ⓜ 🔴 🔴 🔴 🔴 🔴 🔴 🔴 Ⓜ	Internal charger fault	Reset the charger by interrupting AC power for 15+ seconds. Return to service department if fault persists.

Note: This is a Class A product. In a domestic environment this product may cause radio interference, in which case the user may be required to take adequate measures.



APPENDIX B

BATTERY CHARGER USER'S GUIDE

ELiTE



RC900 ELiTE Onboard Charger Original User Manual

This manual contains important safety and operating instructions for this version of the Delta-Q RC900 ELiTE Onboard Charger (Part No. 944-0003) for use with E-Z-GO ELiTE lithium brand vehicles (Model 673928). For manufacturer contact information and technical support, please visit <http://support.delta-q.com/>.

SAVE THESE SAFETY INSTRUCTIONS
This manual contains important safety & operating instructions. Read before using the charger.



Warning

Charge only 48V lithium-ion type batteries activated by Samsung SDI. Other types of batteries may burst causing personal injury and damage. The Samsung Battery Management System (BMS) ensures that in all operating modes, the battery cells are protected from inappropriate levels of voltage, current, temperature, and state of charge. Never charge a frozen or non-rechargeable battery. Study the battery manufacturer's specific precautions before using this charger.



Danger

Risk of electric shock. Connect charger power cord to an AC outlet that has been properly installed and grounded in accordance with all local codes and ordinances. A grounded AC outlet is required to reduce the risk of electric shock—do not use ground adapters or modify the plug. Do not touch uninsulated portions of the output connector or uninsulated battery terminals. Disconnect the AC supply before making or breaking the connections to the battery. Do not open or disassemble the charger. Do not operate this charger if the AC supply cord or DC output cord is damaged or if the charger is damaged in any way. Refer all repair work to the manufacturer, or qualified personnel. This charger is not intended for use by persons (including children) with reduced physical, sensory or mental capabilities, or lack of experience and knowledge on electrical systems and battery charging, unless they have been given supervision or instruction concerning use of the charger by a person responsible for their safety. Children should be supervised to ensure they do not play with the charger.

Manuel d'origine de l'utilisateur du Chargeur À bord RC900 ELiTE

Le présent manuel contient d'importantes consignes de sécurité et d'utilisation pour cette version du chargeur Delta-Q à bord RC900 ELiTE (numéro de référence 944-0003) pour utilisation avec les véhicules de marque E-Z-GO ELiTE alimentés par des batteries au lithium-ion (Modèle 673928). Pour les coordonnées et le soutien technique du fabricant, visitez <http://support.delta-q.com/>.

CONSERVEZ CES CONSIGNES DE SÉCURITÉ
Le présent manuel contient d'importantes consignes de sécurité et d'utilisation.
Lisez-les avant d'utiliser le chargeur.



Attention

Chargez uniquement les batteries au lithium-ion 48 V activées par Samsung SDI. Les autres types de batteries pourraient exploser causant des blessures corporelles et des dommages. Le système de gestion des batteries intégrés garantit que dans tous les modes de fonctionnement, les cellules de la batterie sont protégées contre les niveaux inappropriés de tension, de courant, de température et d'état de charge. Ne chargez jamais une batterie gelée ou non rechargeable. Prenez connaissance des mesures de précaution spécifiées par le fabricant de la batterie avant d'utiliser ce chargeur.



Danger

Risque de décharge électrique. Toujours connecter le cordon d'alimentation du chargeur à une prise de secteur CA proprement installée et mise à la terre conformément à tous les codes et règlements locaux. Une prise secteur CA mise à la terre est nécessaire pour réduire le risque de choc électrique - n'utilisez pas d'adaptateurs de terre et ne modifiez pas la fiche. Ne pas toucher les parties non isolées du connecteur de sortie ou les bornes non isolées de la batterie. Déconnectez la source CA avant de faire ou défaire les connexions à la batterie en chargement. Ne pas ouvrir ni désassembler le chargeur. Ne pas utiliser le chargeur si le cordon d'alimentation CA ou le cordon de sortie CC est endommagé ou si le chargeur est abîmé suite à une chute ou autre incident – Référez toute réparation au fabricant ou aux personnes qualifiées. Cet appareil n'est pas destiné à un usage par des personnes (dont les enfants) avec des facultés motrices, sensorielles ou mentales réduites, ou ayant une expérience et des connaissances insuffisantes, à moins qu'elles sont sous la supervision ou reçoivent les instructions sur l'utilisation de l'appareil par une personne responsable de leur sécurité. Les enfants doivent être surveillés afin qu'il ne jouent en aucun temps avec le chargeur.

Operating & Maintenance Instructions

- ❖ The charger may become hot during charging. Do not touch the charger when it is charging.
- ❖ To maintain safe operations, the unit automatically reduces its output power if the temperature rises above set thresholds, or if the AC input voltage is too low.
- ❖ If power is interrupted, and then returns, the charger starts and continues to operate without hazard to the user, or damage to the batteries.
- ❖ Unplug the vehicle from AC when cleaning, moving, or conducting any maintenance or repair on the vehicle. No user serviceable parts are inside the charger. Do not remove the charger or the cover due to the risk of electrical shock.
- ❖ Do not expose the charger to oil, dirt, mud, or direct heavy water spray when cleaning the vehicle or machine.
- ❖ The enclosure on these chargers meets IP66, making it protected from dust ingress and powerful water jets. The AC receptacle requires an external AC cord which is not protected against dust or water. Protect this AC connection if the charger is used in wet or dusty environments. Inspect it regularly for contamination. If the cord is in a damp location, use a Class A GFCI AC outlet.
- ❖ If the external AC input power cord is damaged, do not use the charger until it is replaced by a qualified service technician with a cord set appropriate to your region and application.
- ❖ To charge your vehicle, use a 3-wire external cord less than 30m (100') at 10 AWG or 7.5m (25') at 16 AWG, per UL guidelines.

AC Receptacle Indicators

The recommended AC receptacle is Delta-Q Part No. 900-0206 (TSV Part No. 673527). For applications outside North America, please use an approved locking and sealing connector on the RC900 Elite.

LED	Indication
Off	No AC Power. Check for AC cord damage; plug into AC power outlet; ensure AC outlet has power.
Slow Green Breathing	More than 80% state of charge.
Fast Green Breathing	Less than 80% state of charge.
Solid Green	Charge Complete
Rapid Amber Flash	Error. Unplug and plug the charger in again. If the error remains, contact a qualified service technician.
Solid Red	Fault. Unplug and plug the charger in again. If the fault remains, contact a qualified service technician.

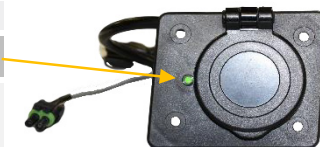

Identifying Charger Serial Number

The serial number is printed on the front of the charger. Use this number when requesting technical support.



This equipment has been tested and found to comply with the limits for a Class B digital device, pursuant to part 15 of the FCC Rules for the United States and the ICES Regulations for Canada. These limits are designed to provide reasonable protection against harmful interference in a residential installation. This equipment generates, uses, and can radiate radio frequency energy and, if not installed and used in accordance with the instructions, may cause harmful interference to radio communications.

Delta-Q Technologies Corp.
 3755 Willingdon Ave.
 Burnaby, B.C. V5G 3H3 CANADA
 Phone: +1.604.327.8244

Email: support@delta-q.com
 Web: www.delta-q.com
 User Documentation: www.delta-q.com/resources

APPENDIX C

BATTERY CHARGER USER'S GUIDE

ELITE

EZ350 Model
Lithium Golf Cart
Battery Charger



Chargeur de batterie au lithium
pour chariot de golf
Modèle EZ350

E-Z-GO ELITE Charger – EZ350 Model Original User Manual

This manual contains important safety and operating instructions for these versions of the Delta-Q ELITE Charger (Part Numbers: 958-0003 and 958-0004) for use with E-Z-GO ELITE lithium brand vehicles. Read this information in its entirety before using your charger. For manufacturer contact information and technical support, visit <http://support.delta-q.com/>.

SAVE THESE SAFETY INSTRUCTIONS

This manual contains important safety & operating instructions. Read before using the charger.



Warning

Charge only 48V lithium-ion type batteries activated by Samsung SDI. Other types of batteries may burst causing personal injury and damage. Never charge a frozen or non-rechargeable battery. Study the battery manufacturer's specific precautions before using this charger.



Danger

Risk of electric shock. Connect charger power cord to an AC outlet that has been properly installed and grounded in accordance with all local codes and ordinances. A grounded AC outlet is required to reduce risk of electric shock – do not use ground adapters or modify the plug. Do not touch uninsulated portions of the output connector or uninsulated battery terminals. Disconnect the AC supply before making or breaking the connections to the battery. Do not open or disassemble the charger. Do not operate the charger if the AC supply cord or DC output cord is damaged or if the charger has received a sharp blow, been dropped, or is damaged in any way. Refer all repair work to the manufacturer or qualified personnel. This charger is not intended for use by persons (including children) with reduced physical, sensory or mental capabilities, or lack of experience and knowledge on electrical systems and battery charging, unless they have been given supervision or instruction concerning use of the charger by a person responsible for their safety. Children should be supervised to ensure they do not play with the charger.

Manuel d'origine de l'utilisateur du Chargeur E-Z-GO ELITE – Modèle EZ350

Le présent manuel contient d'importantes consignes de sécurité et d'utilisation pour ces versions du Chargeur Delta-Q ELITE (numéros de référence 958-0003 et 958-0004) pour utilisation avec les véhicules de marque E-Z-GO ELITE alimentés au lithium. Lisez en entier les informations fournies avant d'utiliser le chargeur. Pour les coordonnées et le soutien technique du fabricant, visitez <http://support.delta-q.com/>.

CONSERVEZ CES CONSIGNES DE SÉCURITÉ

Le présent manuel contient d'importantes consignes de sécurité et d'utilisation. Lisez-les avant d'utiliser le chargeur.



Mise en garde

Chargez uniquement les batteries au lithium-ion 48 V activées par Samsung SDI. Les autres types de batteries pourraient exploser causant des blessures corporelles et des dommages. Ne chargez jamais une batterie gelée ou non rechargeable. Prenez connaissance des mesures de précaution spécifiées par le fabricant de la batterie avant d'utiliser ce chargeur.



Danger

Risque de choc électrique. Branchez le cordon d'alimentation du chargeur à une prise CA qui a été correctement installée et mise à la terre conformément à tous les codes et règlements locaux en matière d'électricité. Une prise CA mise à la terre est requise pour réduire les risques d'électrocution; n'utilisez pas d'adaptateurs de terre ou ne modifiez pas la fiche. Ne touchez pas la partie non isolée du connecteur de sortie ou les bornes de la batterie non isolées. Débranchez l'alimentation CA avant d'effectuer ou de rompre les connexions à la batterie. N'ouvrez pas ou ne démontez pas le chargeur. N'utilisez pas le chargeur si son cordon d'alimentation CA ou son cordon de sortie CC est endommagé ou si le chargeur a reçu un coup violent, s'il est tombé ou s'il a été endommagé de quelque façon que ce soit. Le chargeur ne doit être réparé que par le fabricant ou du personnel qualifié. Ce chargeur n'est pas conçu pour être utilisé par des personnes (y compris les enfants) ayant des capacités physiques, sensorielles ou mentales réduites, ou manquant d'expérience et de connaissances des systèmes électriques et de la charge de batteries, à moins qu'une personne responsable de leur sécurité ne les supervise ou ne leur ait fourni les consignes d'utilisation. Les enfants doivent être supervisés pour s'assurer qu'ils ne jouent pas avec le chargeur.

Maintenance Instructions

- The enclosure on all charger models meets IP56, making it protected from dust ingress and powerful water jets. The AC connection on the 958-0004 model requires an external AC cord and is rated to IP20, which is not protected against dust or water. Protect this AC connection if the charger is used in wet or dusty environments and inspect it regularly for contamination.
- All connectors between the battery charger and the battery should be regularly inspected for corrosion and contamination as these can cause overheating and can be a fire hazard.
- If the AC power supply cord is damaged:
 - ☒ The 958-0003 charger model has an integral AC cord for connection to North American outlets operating at 120 Volts nominal. If this AC power supply cord is damaged, do not use the charger and send it to a qualified service technician for repair.
 - ☒ The 958-0004 charger model has a 7-inch (185mm) AC cord terminated with an IEC 320 C14 plug. If this AC power supply cord is damaged, do not use the charger and send it to a qualified service technician for repair. If the mating AC cord to the wall outlet is damaged, replace it with a 6 feet (1.83 meter) long UL/CSA approved AC cord with a grounded IEC 320 C13 socket rated 250V, 13A minimum on the charger side and an approved 3-prong grounded plug compatible with the local AC power outlet (110VAC to 240VAC). If the 3-prong grounded plug does not fit the local AC power outlet, contact E-Z-GO or Delta-Q Technologies for the proper cord for the local AC power outlet.
 - ☒ For regions with 220-240V mains supply, select a safety approved AC cord, 3-conductor, 1.0mm² minimum, rated appropriately for industrial use. The cord must be terminated on one end with a grounded input connector appropriate for the AC power in the country of destination and, on the charger end, a grounding type IEC 320 C13 socket.

NOTE: This equipment has been tested and found to comply with the limits for a Class B digital device, pursuant to Part 15 of the FCC/ICES Rules. These limits are designed to provide reasonable protection against harmful interference in a residential installation. This equipment generates, uses, and can radiate radio frequency energy and, if not installed and used in accordance with the instructions, may cause harmful interference to radio communications.

Mounting Instructions

The charger can be mounted horizontally or vertically with the cables and LED indicators pointing downward. Five (5) robust mounting points are cast into the charger's aluminum enclosure and another mounting hole in the center of the handle. The charger can be screwed to a table or wall with the four (4) slotted mounting holes, two (2) on each side using M6 or ¼-inch fasteners. A vertical mounting from the single cast keyhole mounting slot opposite the cables is possible using a suitable 8 or 10mm or 3/8-inch J-hook. A suspended horizontal mounting is achieved using a ceiling secured 5/16-inch threaded rod secured with nuts above and below the handle.

Consignes d'entretien

- Le boîtier en tout modèles de chargeur est conforme à la norme IP56, le protégeant ainsi contre l'infiltration de poussière et les jets d'eau puissants. Le branchement CA sur modèle 958-0004 nécessite un cordon CA externe et est conforme à la norme IP20, qui n'offre pas de protection contre la poussière ou l'eau. Protégez ce branchement CA si le chargeur est utilisé dans un environnement humide ou poussiéreux et inspectez le régulièrement pour déceler toute contamination.
- Tous les connecteurs entre le chargeur de batterie et la batterie doivent être régulièrement inspectés pour corrosion et contamination, car ils peuvent provoquer un surchauffage et peuvent être un risque d'incendie.
- Si le cordon d'alimentation CA est endommagé :
 - ☒ Le modèle de chargeur 958-0003 est équipés d'un cordon CA intégré pour le branchement sur les prises en Amérique du Nord fonctionnant à une tension nominale de 120 volts. Si ce cordon d'alimentation CA est endommagé, n'utilisez pas le chargeur et envoyez-le à un technicien de service qualifié pour la réparation.
 - ☒ Le modèle de chargeur 958-004 est équipés d'un cordon d'alimentation CA de 7 pouces (185 millimètre) se terminant par une fiche IEC 320 C14. Si ce cordon d'alimentation CA est endommagé, n'utilisez pas le chargeur et envoyez-le à un technicien de service qualifié pour la réparation. Si le cordon d'alimentation CA d'accouplement à la prise murale est endommagé, remplacez le par un cordon d'alimentation CA approuvé UL/CSA de 6 pieds (1,83 m) de longueur avec une prise IEC 320 C13 reliée à la terre fonctionnant à une tension nominale de 250 V, 13A minimum au côté chargeur et une fiche mise à la terre approuvée à 3 broches compatible avec la prise de courant CA locale (110 V c.a. à 240 V c.a.). Si la fiche mise à la terre à 3 broches ne convient pas à la prise de courant CA locale, communiquez avec E-Z-GO ou Delta-Q Technologies pour connaître le cordon approprié pour la prise de courant CA locale.
 - ☒ Pour les régions utilisant une alimentation secteur 220-240 V, sélectionnez un cordon d'alimentation CA approuvé, à 3 conducteurs, 1,0 mm² minimum, évalué de façon appropriée pour une utilisation industrielle. Le cordon doit se terminer, à une extrémité, par un connecteur d'entrée mis à la terre approprié pour l'alimentation CA dans le pays de destination et, à l'autre extrémité du chargeur, par une fiche IEC 320 C13 mise à la terre.

REMARQUE: cet équipement a été testé et déclaré conforme aux limites pour appareils numériques de classe B, selon la section 15 des règlements de la FCC et de l'ICES. Ces limites sont destinées à assurer une protection raisonnable contre les interférences nuisibles dans une installation résidentielle. Cet équipement produit, utilise et peut émettre de l'énergie radio électrique et, s'il n'est pas installé et utilisé conformément aux présentes instructions, peut causer des interférences nuisibles aux communications radio.

Instructions de montage

Le chargeur peut être monté à l'horizontale ou à la verticale avec les câbles et les indicateurs DEL orientés vers le bas. Cinq (5) points de montage robustes sont moulés dans le boîtier en aluminium du chargeur et un autre trou de montage se trouve dans le centre de la poignée. Le chargeur peut être vissé sur une table ou un mur avec les quatre (4) fentes de montage, deux (2) de chaque côté, à l'aide d'attaches M6 ou de 1/4 de pouce. Un montage vertical à partir de la fente de montage en forme de trou de serrure à l'opposé des câbles est possible à l'aide d'un crochet en J approprié de 8 ou de 10 mm ou de 3/8 po. Un montage horizontal suspendu se réalise à l'aide d'une tige filetée de 5/16 po fixée au plafond avec des écrous au-dessus et en-dessous de la poignée.

Operating Instructions

CAUTION: The charger enclosure may be hot during charging. Use hand protection if handling the charger while charging.

- ☒ The extension cord must be a 3-wire cord less than 30m (100') at 10AWG or 7.5m (25') at 16AWG per UL guidelines.
- ☒ If you are connecting four (4) ELiTE Chargers to a single 120V mains circuit, a 20A circuit is recommended.
- ☒ Battery Capacity: Lithium-ion 14 Cells 50 -120Ah

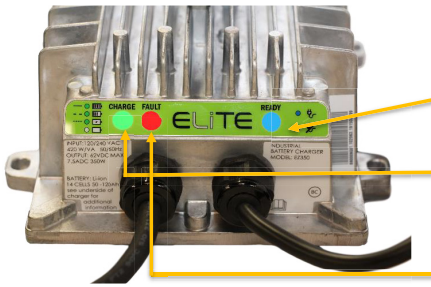

Charger Indicators

Indicator	Indication
● AC Indicator Blue Light	☒ If solid, AC power is present.
● Charger Status Indicator Green Light	☒ If solid, charging is complete. ☒ If slow breathing, it is more than 80% charged. ☒ If fast breathing, it is less than 80% charged.
● Fault Indicator Red Light	☒ Charger error. Refer to <i>Troubleshooting Instructions</i> .

Note: The charger will flash green when the lithium Battery Management System (BMS) is in wakeup mode.

DC Receptacle Indicators

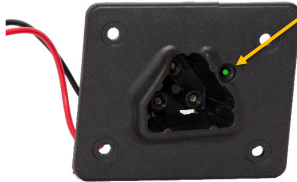

LED	Indication
Solid	Charging is complete.
Slow Flash	More than 80% state of charge.
Fast Flash	Less than 80% state of charge.
Off	See charger indicators for status.

Mode d'emploi

MISE EN GARDE : Le boîtier du chargeur peut devenir chaud pendant le chargement. Utilisez une protection pour les mains si vous manipulez le chargeur pendant le chargement.

- ☒ La rallonge électrique doit être un cordon à 3 fils de moins de 30 m (100 pi) de long à 10 AWG ou 7,5 m (25 pi) à 16 AWG selon les directives UL.
- ☒ Si vous connectez **quatre (4) chargeurs ELITE** à un seul circuit de 120V, un circuit de 20 A est recommandé.
- ☒ Capacité de la batterie: Lithium-ion 14 cellules 50 -120Ah

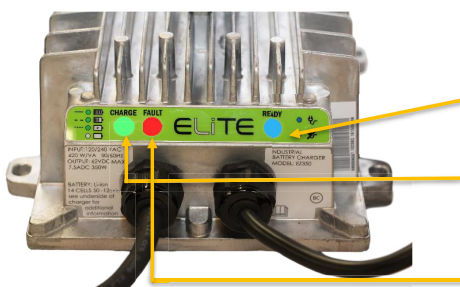

Indicateurs du chargeur

Indicateur	Indication
● Indicateur CA Voyant bleu	☒ Si constant, il y a une alimentation CA.
● Indicateur de l'état du chargeur Voyant bleu	☒ Si constant, la charge est terminée. ☒ Si la pulsation est lente, la batterie est chargée à plus de 80%. ☒ Si la pulsation est rapide, la batterie est chargée à moins de 80%.
● Indicateur de défaut Voyant rouge	☒ Erreur du chargeur. Consultez les <i>Instructions de dépannage</i> .

Remarque: le chargeur clignotera en vert lorsque le système de gestion de la batterie au lithium est en mode d'éveil.

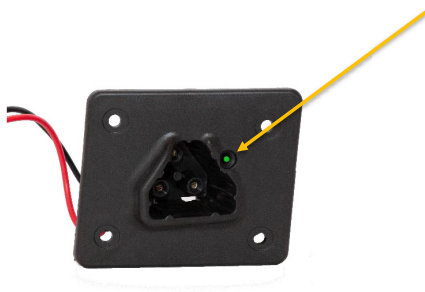











Indicateurs de prise de courant CC

DEL	Indication
Constant	La charge est terminée.
Clignotement lente	Charge de plus de 80%.
Clignotement rapide	Charge de moins de 80%.
Éteint	Voir les indicateurs du chargeur pour l'état.











Troubleshooting Instructions

If a fault occurs, count the number of red flashes between pauses and refer to this table:

Flashes	Cause	Solution
 	The lithium battery pack issued a fault indicating a wiring or charger hardware issue.	Check the green DC paddle and receptacle for damage, corrosion, and ensure it is properly inserted. Reset the charger by interrupting AC power for 15+ seconds. If the fault returns, contact E-Z-GO Customer Care.
  	The charge time or amp-hour limit was exceeded.	Check the green DC paddle and receptacle for damage, corrosion, and ensure it is properly inserted. Ensure the charger has sufficient cooling airflow in ambient temperatures below 40°C; if in the sun, move to the shade. Reset the charger by interrupting AC power for 15+ seconds. If the fault returns, contact E-Z-GO Customer Care.
 	The lithium battery pack shut down charging and issued a fault.	Reset the lithium battery pack by turning the ignition and tow mode off, remove the green charger paddle from the receptacle, wait 5+ seconds, re-insert the paddle. If the fault returns, contact E-Z-GO Customer Care.
  	Internal charger fault	Reset the charger by interrupting AC power for 15+ seconds. If the fault returns, contact E-Z-GO Customer Care.

Instructions de dépannage

S'il survient une erreur, comptez le nombre de clignotements rouges entre les pauses et reportez-vous au tableau suivant :

Clignotement	Cause	Solution
 	Le bloc-batterie au lithium a émis un défaut indiquant un problème de câblage ou de matériel du chargeur.	Vérifiez la palette CC verte et la prise pour vous assurer qu'il n'y a pas de dommage ou de corrosion et assurez-vous qu'elle est bien insérée. Réinitialisez le chargeur en interrompant l'alimentation CA pendant 15 secondes ou plus. Si le défaut revient, communiquez avec le service à la clientèle E-Z-GO.
  	La limite de temps de charge ou d'ampères par heure a été dépassée.	Vérifiez la palette CC verte et la prise pour vous assurer qu'il n'y a pas de dommage ou de corrosion et assurez-vous qu'elle est bien insérée. Assurez-vous que le chargeur a suffisamment de circulation d'air de refroidissement dans les températures ambiantes inférieures à 40° C. Si le chargeur est au soleil, mettez-le à l'ombre. Réinitialisez le chargeur en interrompant l'alimentation CA pendant 15 secondes ou plus. Si le défaut revient, communiquez avec le service à la clientèle E-Z-GO.
 	Le bloc-batterie au lithium a arrêté la charge et a émis un défaut.	Réinitialisez le bloc-batterie au lithium en coupant l'allumage et en désactivant le mode de remorquage, enlevez la palette verte du chargeur de la prise, attendez 5 secondes ou plus et réinsérez la palette. Si le défaut revient, communiquez avec le service à la clientèle E-Z-GO.
  	Défaut interne du chargeur	Réinitialisez le chargeur en interrompant l'alimentation CA pendant 15 secondes ou plus. Si le défaut revient, communiquez avec le service à la clientèle E-Z-GO.

CHANGE OF ADDRESS, OWNERSHIP, OR WARRANTY TRANSFER

Textron Specialized Vehicles keeps on file the current name and address of the owner of this vehicle. This allows us to contact the current owner with any important safety information which may be necessary to protect customers from personal injury or property damage. Please make sure a copy of this form is completed and return to us if your address changes or if the vehicle is sold to another party.

This form may also be used to transfer the unused portion of the original warranty to a second party. To request a transfer of warranty, fill out this form completely and return a copy to us. The request will be processed and the balance of the remaining original warranty will be issued. Warranty coverage is only available in the country in which the original retail purchase occurs by the original retail purchaser resident in that country, or to a transferee resident in that country of the balance of the warranty.

- Address Change
- Ownership Change
- Warranty Transfer

CHANGE OF ADDRESS/OWNERSHIP/WARRANTY TRANSFER TO:

Name _____

Address _____

City/State (Province) _____

Zip Code (Postal Code) _____

Phone () _____

Email _____

Year and Model _____

Vehicle Identification Number (VIN) _____

CUT LINE

FOLD

CHANGE OF ADDRESS/OWNERSHIP OR WARRANTY TRANSFER

Place
Stamp
Here

**TEXTRON SPECIALIZED VEHICLES
1451 MARVIN GRIFFIN RD
AUGUSTA GA 30906-3852
USA**

ATTN: WARRANTY DEPARTMENT

Normal use, age and wear on vehicle components can affect the safe operation and reliability of the vehicle. The recommended inspection and maintenance procedures are crucial for safety, performance, reliability and maximum longevity of your vehicle.

A damaged vehicle, or a vehicle that is not functioning properly is dangerous and must not be operated until repairs are made.

NOTICE: Read the following operational warnings before driving the vehicle:

Before you leave the vehicle, turn the key to the OFF position and remove the key from the vehicle to prevent unauthorized use.

WARNING

Drive the vehicle at appropriate speeds for the terrain and conditions. Be aware of environmental conditions that change the terrain and your ability to control the vehicle.

Do not drive on excessively steep hills. Evaluate the terrain before descending a hill. Drive slowly and deliberately. Use the brake to limit speed and maintain control. Sudden braking or turning can cause loss of vehicle control. Drive straight down the hill; do not drive across the hill.

Operate only in approved areas.

Keep feet, legs, hands and arms inside vehicle at all times.

Avoid driving on terrain that is too rough for your vehicle's capabilities and your driving skills.

Before you drive in the reverse direction, make sure the area behind the vehicle is clear. Accelerate slowly and avoid making sharp turns.

Make sure the direction selector is in the correct position before you press the accelerator pedal.

Decrease speed before and during turns.

Bring the vehicle to a complete stop before you move the direction selector.

See GENERAL SPECIFICATIONS for the vehicle load and seat capacity.

NOTICE: Read the following maintenance information and warnings before servicing or repairing the vehicle:

Follow the procedures and comply with the safety information in this manual while performing vehicle service or maintenance.

Use the tools shown in the tool list and wear the specified safety equipment when performing vehicle service or maintenance.

WARNING

Remove all jewelry before you service the vehicle.

Do not allow loose clothing or hair to contact the moving parts.

Do not touch hot objects.

The drive wheels must be lifted and supported on jack stands before you perform any service to the powertrain while the motor is in operation.



When you service the vehicle, always wear eye protection. Be careful when working around batteries, using solvents or compressed air.

Use insulated wrenches to decrease the risk of a short-circuit if a wrench contacts the battery terminals. A short-circuit in a battery can cause an explosion.

To prevent the risk of battery explosion, keep all flammable materials, open flames or sparks away from the batteries.

Maintain constant awareness that some components are heavy, spring loaded, corrosive, explosive, can cause high amperage or get extremely hot. Battery acid and hydrogen gas can cause bodily injury. Keep your hands, face, feet and body away from any area that can expose them to injury if an unexpected situation occurs.



TEXTRON SPECIALIZED VEHICLES, INC.

1451 Marvin Griffin Road
Augusta, Georgia 30906 - 3852
USA

CONTACT INFORMATION

North America:

Technical Assistance & Warranty:

Phone: 1-800-774-3946, FAX: 1-800-448-8124

Service Parts Phone:

1-888-GET-E-Z-GO (1-888-438-3946), FAX: 1-800-752-6175

International:

Phone: 001-706-798-4311, FAX: 001-706-771-4609

California Proposition 65



WARNING

Operating, servicing and maintaining a passenger vehicle or off-road vehicle can expose you to chemicals including phthalates and lead, which are known to the State of California to cause cancer and birth defects or other reproductive harm. To minimize exposure, wear gloves and wash your hands frequently when servicing your vehicle.

For more information go to www.P65Warnings.ca.gov/passenger-vehicle

Parts Manuals and Service Manuals are available from a local Distributor, an authorized Branch, Genuine E-Z-GO Parts & Accessories Department or at www.shopezgo.com.

Copyrighted Material

This manual may not be reproduced in whole or in part without the express permission of the manufacturer.